

Facilitators Manual for Community Workshops

Inter-Agency *Peace* Education Programme

Skills for Constructive Living



INEE

**Inter-Agency
Peace Education Programme**

Skills for Constructive Living

Facilitator's Manual for Community Workshops

The ideas and opinions expressed in this work are those of the author and do not necessarily reflect UNESCO's point of view.

Editorial coordination: Antonella Verdiani, UNESCO ED/PEQ/PHR

UNESCO, United Nations Educational, Scientific and Cultural Organization (<http://www.unesco.org>).

INEE, the Inter-Agency Network for Education in Emergencies, is an open network of UN agencies, NGOs, donors, practitioners, researchers and individuals from affected populations working together to ensure the right to education in emergencies and post-crisis reconstruction (www.ineesite.org).

Published in 2005 by the United Nations Educational, Scientific and Cultural Organization

7 Place de Fontenoy
75352 Paris 07 SP - France
ED-2005/WS/50 //cld 24854

© UNESCO - INEE, November 2005

Printed in France

Foreword

In recent years there have been numerous conflicts across the globe, which have led to suffering and displacement of millions of children and young people, often under horrific circumstances. The world's poorest countries are most frequently those torn apart by internal conflict. Many countries face desperate poverty that aggravates internal division with the possible consequence of violence. Other desperately poor countries suffer the destabilizing effect of conflict in neighbouring states.

The programme that has been developed in these materials provides the life skills related to peace education and conflict minimisation and prevention to reach refugee and returnee children, youth and the wider community. These life skills will enable the participants to deal with related problems, including the social fragmentation problems of sexual harassment and exploitation, access to education (especially for girls), community caring as well as skills for constructive and non-violent living.

The United Nations Educational, Scientific and Cultural Organization (UNESCO) has collaborated with the United Nations High Commissioner for Refugees (UNHCR) to strengthen these constructive skills for living through the present "Inter-Agency Peace Education Technical Support Programme". This initiative has been made possible through the generous support of the Ministry of Foreign Affairs of Norway, Section for Humanitarian Affairs, Global Affairs Department, through the Funds in Trust programme of UNESCO which partly financed it from January 2004 to June 2005. UNHCR, in particular, has initiated and supported this programme from its inception in 1997 and has generously contributed financially and to its implementation in the field, in partnership with UNOPS.

In its mandate, UNESCO is committed to education for peace, human rights and dialogue between different cultures and civilizations. The Dakar "Education For All" (EFA) Plan of Action includes these principles and emphasizes the need to improve all aspects of quality education. In this framework, UNESCO has been concentrating special efforts in the crucial area of teacher training, with particular emphasis in African countries: this is also in accordance with the Norwegian strategy in multi-lateral and bi-lateral cooperation of making effective use of the funds to maximize concrete changes in developing countries.

The programme has been built on the solid foundation of the earlier Peace Education Programme developed by UNHCR since 1997, and later on adopted by the Inter-Agency Network for Education in Emergencies (INEE). It was upgraded with the input of both refugees and the host community. It also incorporates lessons learned from the external evaluation undertaken of the UNHCR programme in 2002 and has further responded to stated needs of people in both emergency and development situations. Education planners, teachers, refugee and returnee communities, staff of the UN partners as well as government authorities will find these materials useful for their peace-building efforts, especially if they have been trained on how to use them.

The work has benefited from the contributions of many students, community members, teachers and facilitators as well as UN and NGO personnel, too numerous to mention individually. However, special appreciation should be expressed to colleagues in UNESCO, especially the Division for the Promotion of Quality Education, in UNHCR, the Division of Operational Support and in UNOPS, the United Nations Office for Project Services in Geneva. A special acknowledgement should be given to the Senior Technical Adviser, Pamela Baxter, for the work and energy devoted to the project. The support of Margaret Sinclair, who was the originator of this programme, Anna Obura, whose evaluation provided both evidence of positive impact and valuable lessons learned and Jessica Walker-Kelleher, Jean Anderson and Karen Ross, who took on the task of upgrading the primary section of the formal education component, are likewise acknowledged.

The value of these endeavours and contributions will be multiplied, to the extent that the skills for peace-building, incorporated in these materials, become a standard component in situations of emergency and crisis, and for conflict prevention and reconstruction.

Mary Joy Pigozzi
Director
Division for the Promotion of Quality Education
UNESCO

Marjon Kamara
Director
Division of Operational Support
UNHCR

Introduction

This manual is one of the components of the “Inter-Agency Peace Education Programme”. The programme is designed for education managers of ministries dealing with both formal and non-formal education and for agencies which implement education activities on behalf of the government.

The implementation structure is based on the experience acquired over the eight years the programme has been in use, from 1998 to 2005. The programme has been evaluated by external experts and the new revised materials (2005) incorporate both the suggestions made in the evaluation and the feedback from the specialists who implemented it in the field.

Historically this programme has been restricted to refugee communities. However, it has expanded and moved into both refugee and returnee situations. With the partnership between UNESCO and UNHCR, in the framework of the Funds-in -Trust “Inter-Agency Peace Education Technical Support Programme” financed by the Ministry of Foreign Affairs of Norway in 2004 -2005, the project has been further developed to respond to the needs in situations of emergency and reconstruction and also into development situations as well. The programme is currently being implemented in eleven countries in Africa¹ and has been integrated into complementary initiatives in Sri Lanka, Kosovo, and Pakistan.

The following is the table shows the list of materials and their uses which are the components of the Peace Education Programme. For a more complete presentation, see the booklet “Overview of the Programme”.

The Materials²

Overview of the programme	A description of the components of the Peace Education Programme and the implementation structure of the programme.
Teacher Activity Kit Teacher Activity Book (TAB)	The teacher’s main resource. It has a lesson-by-lesson curriculum for formal schooling, structured according to the children’s cognitive and emotional development. Each teacher working in the programme needs his or her own copy of the kit.
Charts	Teaching resources (not teaching aids).
Story Book	More than thirty stories and songs which are referred to in the TAB. Each story reflects a particular aspect of Peace Education or responds to particular needs in the community (for example: HIV/AIDS, gender equality, girls’ access to school).
Proverb Cards	Local proverbs for use especially in the ‘analysis’ lessons in the middle primary.
Community (Adult) Programme Facilitator’s Manual for Community Workshops	A guide for facilitators conducting the Community Programme. Each facilitator should have a copy of this book.
Community Course Booklet	A handout booklet, which outlines the major concept areas covered in the community course.
Training Manuals Teacher Training Manual Level 1, Level 2 and Level 3	These manuals introduce teachers to the psychology of the course, curriculum theory, the rights-based approach and specifics of teaching the Peace Education Programme.
Facilitators Training Manual Level 1, Level 2, Level 3	In three parts, introducing the facilitators to the principles of adult learning, a rights-based approach and the psychology of learning as well as the specifics of the course.
Background Notes for both Teachers and Facilitators	A summary of the major points covered in the training sessions to be used as a reference.
Facilitators and Trainers Training Guide	A small booklet of training hints to ensure that the trainers have the basic skills and use interactive methodology.

1. In order of implementation: Kenya (1998), Uganda (1999), Liberia (1999), Guinea (2000), Sierra Leone (2000), Democratic Republic of Congo (2000), Ethiopia (2000), Eritrea (2001), Cote d’Ivoire (2001) – but currently not operating, Somalia (2004), South Sudan (2004), Ghana (2004).

2. The titles in bold and underlined are separate sections of the programme. Titles in bold are separate books.

Index

Background	6
<i>Contents of the Peace Education Programme</i>	6
Key points for facilitators	7
Session 1	8
<i>Introduction of the facilitator and the participants, and course expectations</i>	8
<i>Background to the course</i>	9
<i>Conflict management theory</i>	11
Session 2	14
<i>Who Are You?</i>	14
<i>Similarities and differences</i>	15
<i>Inclusion and exclusion</i>	16
Session 3	18
<i>Trust</i>	18
<i>Communication (active listening)</i>	21
Session 4	24
<i>Communication and miscommunication</i>	24
<i>One-way and two-way communication</i>	26
<i>Perceptions</i>	29
Session 5	31
<i>Bias</i>	31
<i>Stereotypes, prejudice and discrimination</i>	36
Session 6	40
<i>Emotions</i>	40
<i>Empathy</i>	41
<i>Cooperation</i>	47
<i>Assertiveness</i>	50
Session 7	57
<i>Emotional honesty</i>	57
<i>Problem-solving</i>	58
Session 8	72
<i>Problem-solving continued (six steps)</i>	72
<i>Negotiation</i>	76
Session 9	80
<i>Mediation</i>	80
<i>Reconciliation</i>	82
Session 10	86
<i>Human rights</i>	86
<i>Human Rights and Duties Quiz</i>	90
Sessions 11/12	96
<i>Real-life problems and conflict resolution</i>	96
Appendices	99

Background

This manual is a guide to the way the course should be constructed. It gives activities and handouts as well as an idea of some information on the philosophy of peace education. This version is the seventh revision. The revisions are based on the on-going analysis and evaluation of the materials by those working in Peace Education.

A companion booklet – *Peace Education Programme . Community Course Booklet for Participants of the Community Workshops* – gives examples of role-plays, activities and discussions undertaken in the initial workshops.

Contents of the Peace Education Programme

Formal Education

The Teacher Activity Book

Role Play Cards

Proverb Cards

Charts

Posters`

Peace Education Programme: Story Book

Peace Education Programme: Skills for Constructive Living: Teacher Training Manual*

Peace Education Programme: Skills for Constructive Living: Teacher Training Manual*
Background Notes for Teachers *

Community Education

Peace Education Programme
Facilitator's Manual for Community Workshops

Role Play Cards

Posters

Peace Education Programme.
Community Course Booklet for Participants of the
Community Workshops

The Youth Manual

Facilitators' and Trainers' Training Guide*

Facilitators' Resource Notes*

Resource Book

* These are training materials only.

In addition there is a report on the Pilot Project Phase of the Programme, a report on Formative Evaluation of the Community Workshops, A Baseline Study Report and a report on the Analysis of Materials.

Key points for facilitators

The course is designed to take place in a series of twelve 3-hour sessions. The course should be open to all members of the community, ensuring that there is an age, geographic, status and gender mix (at least over time; it may be preferable or practical to separate language or sex groups initially). The course is designed for people to have a safe structured space to discuss the issues, values and attitudes related to peaceful and constructive living.

Remember the four sections of any curriculum. All of these in combination will enable you to conduct a successful course.

Content

Preparation is essential. Keep the objectives of the session clearly in mind and help participants to reach this point. Remember **TTT** – **tell** what you are going to do; **teach** (using a variety of approaches) and **tell** what you have just done (summaries and conclusions).

Methodology

Variety and pace! The key method in the Peace Education Programme is the Socratic method, discovery or exploratory learning. This is to ensure that participants have psychological ownership of the information (giving information means the information belongs to the lecturer).

Methods need to match the objectives:

- Group work (divergent or convergent) to get participants' views and ideas; pairs work for sharing of sensitive issues.
- Lectures for instructions or information.
- Role plays, discussions and structured activities to explore new issues and to help solve problems.

Environment (physical and psychological)

Arrange the furniture so that participants can see and talk to each other as well as to you. Make sure that you can move around the room. Never stand in front of the window with light behind you (you will be a silhouette).

Your manner is the major part of the psychological environment. It is your responsibility to ensure that participants feel comfortable enough to share their views. This requires you to remain warm and friendly. **Never** make a fool of a participant and remember that the key features of Human Rights are dignity and respect. If you respect others, they will respect you.

Product/outcomes

- The product or outcomes from any training should be real. If participants make recommendations or decisions, ensure that these are followed.
- Ask participants to summarize what has been learned during a session or a day. This can be done through revision sessions built into the course. Make this a quiz or some form of game. The participants should be able to discuss and build on each other's responses.
- If you use written evaluation sheets, make sure that you leave enough time for them to be completed and make sure that they are anonymous (i.e. do not ask for people's names). If it is possible, ask them to complete their evaluation sheets two weeks after the course. This gives a real indication of the value of the course.

SESSION 1

180 minutes

Introduction of the facilitator and the participants, and course expectations

Instructions

- ▶ Introduce yourself as the facilitator, write your name clearly on the board, and tell how you became involved in Peace Education and how you became a facilitator. If it is appropriate, tell a little about yourself and your background.
- ▶ Give each participant a blank card and ask them to write their names and two things they hope to learn from the course.
- ▶ Put all the cards in a box and mix them up.
- ▶ Ask the participants to select a card, find that person, introduce themselves and find out more about the person whose card they have.
- ▶ Ask participants to introduce the person whose card they have to the rest of the group.

- ▶ Form the participants into small groups and ask them to discuss what they would like to learn in this workshop.
- ▶ Ask the groups to prioritize what they would like to learn and record it.
- ▶ Share these lists with the full group.
- ▶ Summarize the expectations of the participants onto a flip chart, ask the participants if they agree that this is what they expect and hang the chart on a wall for later in the course.

Teaching point

As well as an introduction, this exercise is to help the participants to focus on the course and its potential outcomes. It is also to guide you (the facilitator) in identifying the direction that is most appropriate for this particular group of participants.

Background to the course

Instructions

- ▶ Explain to the participants that they are going to do a brainstorm Activity.
- ▶ Ask the participants 'what is peace?' (What do we mean by peace?)
- ▶ Record all the responses on the board or flip chart and then ask: 'what is conflict?' (What are the causes of conflict?)
- ▶ How do we minimize the causes of conflict?
- ▶ Point out that this course actually attempts to help the participants to further develop constructive skills and attitudes.
- ▶ Ask participants to look again at the causes of conflict.

Make sure that you know how to conduct a brainstorm Activity, show the Activity chart if necessary and go through the rules of brainstorming with the group.

Activity

- ▶ As a large group categorize the conflicts into internal and external (e.g., colonialism is often cited as a cause of conflict as is greed. Colonialism is external, greed is internal, but colonialism is in fact just greed on a very large scale).

Is conflict internal or external?

Most conflicts start within (a person) and become more complex and 'externalized' if they are not dealt with. External conflicts are often those that are managed rather than resolved. True resolution of conflict can only come when we deal with those elements of conflict that are internal.

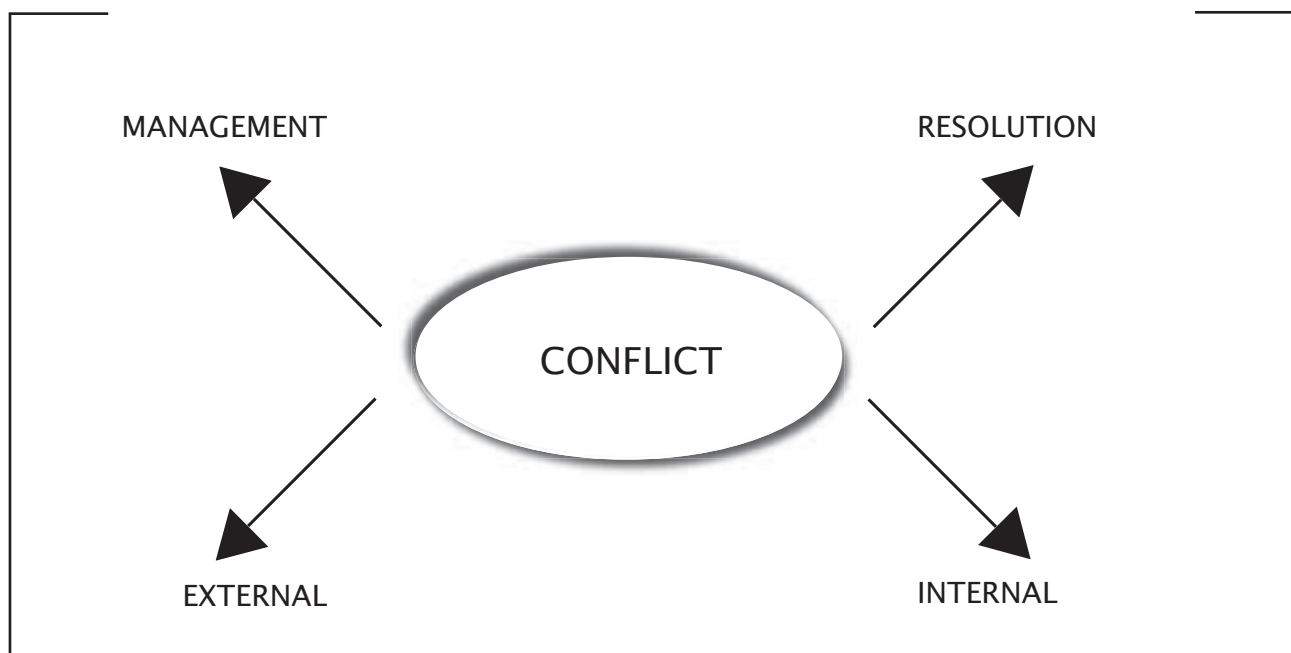

Discussion

- ▶ Ask participants to give examples of internal conflict that may be externalized.
- ▶ Ask generally what happens when this conflict is externalized.
- ▶ If appropriate ask the participants to develop a role play to illustrate the externalizing of conflict.

The aim of this course is to concentrate on the internal resolution side of the model by concentrating on those skills and attitudes that belong to the individual. The world is made up of individuals and, once empowered, individuals can affect the leaders and the decisions made on their behalf.

The first half of the sessions will concentrate on internal skills and attitudes that will help each of us to be at peace with ourselves and to understand what elements each of us carries that create conflict. The second half of the sessions will concentrate on skills that will help us to be better peacemakers within our communities.

WHEN I WAS A CHILD I THOUGHT I COULD CHANGE THE WORLD.
WHEN I WAS A YOUTH I THOUGHT I COULD CHANGE MY COUNTRY
WHEN I MARRIED I THOUGHT I COULD CHANGE MY FAMILY
NOW I AM DYING AND I REALIZE THAT I CAN ONLY CHANGE MYSELF
AND PERHAPS BY CHANGING MYSELF I COULD CHANGE MY FAMILY,
AND THEN MY COUNTRY AND FINALLY THE WHOLE WORLD

Inscribed on a twelfth century tomb.

Teaching point

To emphasize that the focus of this course is the internal resolution of conflict as it is not possible for us to change the world without first changing ourselves.

Conflict management theory

Conflict management continuum

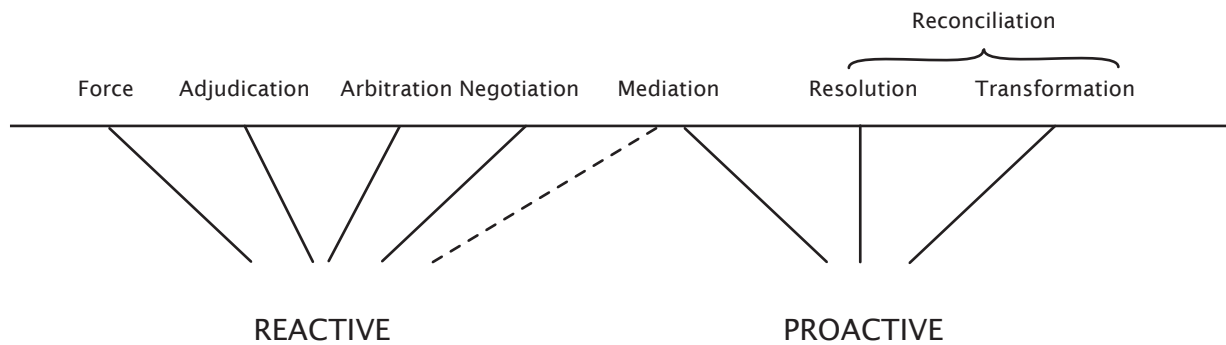

- Explain the conflict management continuum. Both sides or parties in the conflict should undertake conflict management.

Force is usually violence. The views of one party are forced upon the other party and so 'accepted' by them. This has the lowest level of mutual participation as one party is forcing its views on the other party.

Adjudication is the legal system that operates in society. It is a third party outside the two conflicting parties. The third party however has legal/judicial backing and can force the parties to comply. This requires all three parts of the legal system: someone to catch the wrongdoer (usually the police), someone to judge the wrongdoer and some form of punishment or penal system. This requires a stable society so that all three components exist and can work effectively without corruption.

Arbitration has more mutual participation as the two parties can choose the arbitrator and they choose to abide by the decision reached. The only backing the arbitrator has is through the pressures of society to make the two parties conform to the decision made by them and the arbitrator. Traditional law is very close to arbitration as the whole society helps to enforce the punishment.

Negotiation occurs without a third party; the two parties attempt to work out their differences themselves, but the resolution often depends on the power or perceived power of one of the parties and leaves either party able to withdraw from the negotiations.

- These conflict-handling approaches are primarily conflict management. They do not occur until after there is a conflict. As well, they do not attempt to resolve the underlying causes of the conflict.

Mediation is facilitated negotiation. It is positioned to the right of negotiation (on the continuum) because both parties have agreed to the idea of resolving the conflict rather than managing it. The mediator does not make the judgement; instead, the mediator facilitates the resolution.

Resolution is a mutual attempt to resolve the problem in such a way that relationships are constructively changed through the resolution of the problem. This does not mean that all the emotions have been resolved but the problem itself is resolved.

Reconciliation is when there is a durable solution. This is when true peace begins to grow. It means that there are no signs of resentment and there is a 'win/win' solution, so that both parties feel positive about the constructive outcome.

Transformation, which is the highest level of mutual participation, is where there is a conscious decision by both parties to build new and better relationships (i.e., it impacts on the affective domain as much as on the cognitive domain). It is the practical manifestation of the changed attitudes and behaviour when there is no chance of the conflict reoccurring.

- ▶ These conflict-handling approaches can be conflict prevention and minimization as well as management. They should occur before a conflict erupts. This is why they are proactive. As well, these conflict management approaches work to resolve the underlying causes of the conflict so that there is a sustainable solution.

- ▶ The conflict management continuum shows which techniques are reactive forms of managing conflict and which are proactive (forward-looking) forms of managing conflict.
- ▶ Conflict suppression and conflict management are reactive forms. Generally there is no effort to understand the root causes of conflict; in some cases there is no effort made to even listen to both sides of the story.
- ▶ Reactive forms of conflict management are limited and the 'peace' gained this way is also limited. In this situation we see waves of conflict or cycles, with a strong element of revenge (as a result of being suppressed the previous time).
- ▶ Conflict resolution, and conflict prevention and transformation are the most proactive forms of conflict management and the most difficult. There is a renewed interest all around the world in these proactive approaches.

[Appendix 1]

Activity

Tell this story and ask participants to say which forms of conflict management are used at the various points in the story.

Two women were fetching water at the water point. A fight developed over who was first. The guard intervened by separating the women and seizing their buckets. [*Force*] The two women returned home full of anger. One woman decided to take the other to court. One woman was found guilty and fined. Although she paid the fine, the two women were still full of anger at one another. [*Adjudication*] As they left the court, an elder saw that they were unhappy. The two women agreed to talk to this elder and she listened to both sides of the story and solved the problem traditionally. [*Arbitration*] However, both women had resentment in their hearts and one realized that this would sour relationships in the village. So she decided to try to talk to the other woman. When they talked each defended their actions, but they began to listen to each other as well, and they resolved to put the matter behind them [*Negotiation*]. One woman still felt resentful (as she had to pay the fine) and she went to a wise woman in the community who agreed to help. Both women told their story to the wise woman and she helped them to see that they had both been wrong and that they had held resentment from a previous disagreement. [*Mediation*] After guiding them through the discussions and helping them to see their faults, the two women apologised to each other and forgave each other for the wrongdoing. [*Resolution*] To prove that there had been forgiveness they decided to create a garden together and grow vegetables to sell in the market. [*Reconciliation*] They made a lot of money for their families and both women could send their children to school. [*Transformation*]

Teaching point

It is not necessary to work through each of the methods of conflict management. We should, however, be trying to use the most constructive and sustainable techniques (which means those at the right hand or proactive end of the continuum).

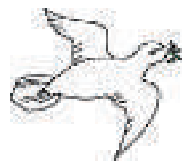

SESSION 2

Who Are You?

90 minutes

Instructions

- ▶ Begin by describing who you are, name, relationships (married or single, parent), what you do, where you come from, etc.
- ▶ Ask participants who they are. This can either be done around the room asking individuals who they are, or each participant can be asked to write who they are.
- ▶ Ask various participants to read what they have written about themselves. *[It is worth moving around the group and reading some of the statements so that the most comprehensive ones can be chosen.]*
- ▶ Ask the group which of the things they have written they have a choice about. e.g. do you have a choice about being male or female, a choice about your colour, your tribe or clan or ethnicity or nationality? Do you have a choice about the work you do, the hobbies you have, etc.
- ▶ Ask the participants on what basis the groups that we belong to are formed. *These are usually on the basis of colour, gender, ethnicity, clan, etc.]*
- ▶ Ask the participants why they think that the group is based on these divisions (which, after all, nobody has any control over).
- ▶ Discuss with the group what responsibilities and rights they think they have (culturally) because of who they are.
- ▶ Discuss whether the groups that we belong to are subject to stereotypes. What stereotypes are they? *[Allow open discussion.]*
- ▶ Do these stereotypes lead to discrimination?
- ▶ Do people in the group discriminate against any other groups? Why?



Similarities and differences

45 minutes

Instructions

- ▶ Put the participants into small groups of four to six.
- ▶ Ask them to list twenty ways in which people from different nationalities or ethnic groups are similar.
- ▶ Tell them that only five of these can be physical similarities. The others must be emotional, spiritual, mental or attitudinal. [Belief in God is a similarity, the way we worship (Religion) is a difference; love for family is a similarity, the fact that we live in social groups is a similarity although the way that we form our societies may be different.] 'Cut me and I bleed, the same as you'
- ▶ Ask the groups to share their lists with the large group, but not to repeat any that have already been listed. Record the combined list on the board or flipchart.
- ▶ When there is a combined list, discuss the similarities and point out that these attitudes and feelings are common to all people.
- ▶ The small groups are to list all the elements in the comprehensive list that do not apply to their group.
- ▶ Combine the lists as before and discuss why one list is longer than the other.

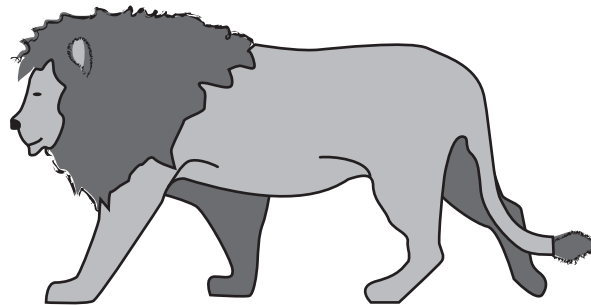

Are the cat and the lion similar or different?

Teaching point

The aim is to find more similarities than differences. The differences are what allow exclusion; the similarities are what allow inclusion.



Inclusion and exclusion

60 minutes

Instructions

- ▶ Ask the participants to think back to Session 1 about the groups that they belong to.
- ▶ Ask if these groups exclude people. Do they exclude people who are actually similar?
- ▶ Discuss with the participants that, when we create a group, we exclude certain people; this is what makes a group, the fact that some people are not part of the group.
- ▶ Ask if the groups that they belong to have advantages by being that group? (Particular tribes, men over women, rich over poor, etc.)
- ▶ Sometimes the formation of groups leads to conflict without anything else happening; the fact that some people are excluded can lead to resentment and a wish to create a rival group.

Activity

Play exclusion game

- ▶ Ask the participants to form a circle and stand together very closely so that nobody can get into the circle.
- ▶ This may need to be done with a single sex group depending on the culture of the participants (i.e. whether it is acceptable for opposite sex participants to hold hands).
- ▶ Keep one (extroverted) person outside the group and then ask that person to try to join the circle.
- ▶ Note what the person who was excluded does and says when excluded from the circle. [*Did the person beg, try to find similarities, try to bribe, or try to force his/her way in?*]
- ▶ Ask the group what happens in real life when people are excluded from groups.
- ▶ Do they react in similar ways to the person in the game?
- ▶ Do they go and create their own group?
- ▶ Do they return to the original group with their new group members?
- ▶ When the group is sitting down again, ask the person who was excluded how he/she felt when excluded and how his/her feelings changed when trying different ways of entering the circle.

Focus discussion

- ▶ Discuss what impact groups have on the way we live and the level of peace that we have.
- ▶ Ask the participants to name some of the groups who are excluded by others.
- ▶ Ask what this does to the people who are excluded.
- ▶ Discuss why people who are HIV positive (HIV+) are often excluded.
- ▶ Ask participants if they are excluded because they have a disease or because of fear or because they have broken moral codes of the society.
- ▶ Ask if the participants think this is fair. Ask about other people who have diseases: are they excluded from society?
- ▶ If appropriate, ask if religion asks people to have compassion for those who are less fortunate.
- ▶ Ask how this changes the view of exclusion.
- ▶ Point out the because of the work done on similarities, now that people understand how similar we all are, that it is not really possible to exclude others and by so doing discriminate against them.

Make sure that you and the participants are aware of how HIV/AIDS is spread and that it is not possible to catch it by sharing cups and plates or using the same latrines, etc. It is not witchcraft or a curse.

It can only be spread by having unprotected sex; by sharing needles; by infected blood on an open wound, and sometimes if a pregnant woman is HIV+ the baby may be born with HIV .

It cannot be cured by sleeping with a virgin, or by traditional healers. It is a new disease and needs to be treated with new medicines. At the moment there is no cure.

Teaching point

Inclusion and exclusion are usually based on compulsory groupings and these groupings are used as a basis for stereotyping and discrimination.



SESSION 3

Trust

90 minutes

Instructions

- ▶ Ask the participants whom they trust.
- ▶ Ask if this trust is equal. In other words do they trust all their relatives or tribal members or people in their village equally? What are the differences?
- ▶ Generally we trust those we know. If we think of the people closest to us, they tend to be also those whom we trust. As people are more removed from us, so we trust them less.

[See figure below]

- ▶ Discuss the idea that trust develops as we get to know the other person or group but we must be prepared to be open to the other person or group and to leave our suspicions behind. Without communication and an attempt to understand another group or person, no trust can be built.

Explain to the participants that during this course, participants in this group will (hopefully) trust the other people in the group more as they get to know them.

The group should also develop trust in you as the facilitator. In addition, as peacemakers whom other people may confide in for conflict resolution, it is important for the participants to engender trust and know when other people trust them.

- ▶ Ask how suspicions grow.
- ▶ Discuss how value-laden language, even when it is not meant to be harmful, gives a certain picture to other people.
- ▶ Discuss words such as traitor, collaborator, bandit, freedom fighter, informer, arrogant, gentle, submissive, selfish, aggressive, etc. What is the story behind each of those words?
- ▶ If these words are used about people we do not know, are we inclined to trust them?
- ▶ What happens when trust is broken? Where are those people in the trust circle?

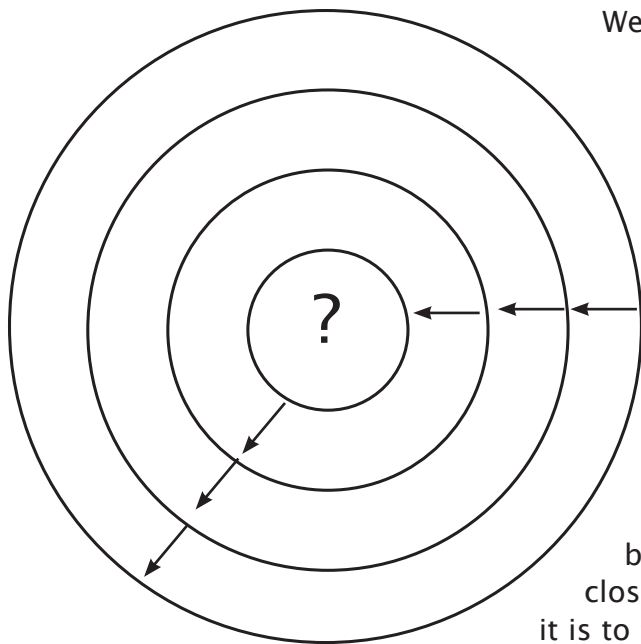

We establish contacts and interact with people we do not know. With some suspicion, we begin to trust them. As the trust increases, the person begins to draw closer to us in the circle.

However, people who are close to us can also break trust and, when this happens, we tend to move them outside the circle and away from us. This exclusion is usually because people who break trust have betrayed the person who trusted them. The closer they are to the centre, the more difficult it is to forgive the betrayal. If there is a commitment between the people, then the trust breaker may be 'given a second chance' and, in some instances, when given a chance, some people improve in their relationship even when they have failed before.

Activity 1

- ▶ Ask the group (or part of the group) to stand in a circle while you stand in the middle. *[Make sure that the radius of the circle is smaller than your body length.]*
- ▶ Tell them to stand close together and ask them if they can be trusted. Turn around in the circle asking each part of the circle if you can trust them and then just fall *[preferably sideways]*.
- ▶ The shock of you falling and them having to catch you is a good tension breaker and it is easy to point out how much they can be trusted.

OR

Activity 2

- ▶ Ask the group to stand in a circle (this may need to be a single sex circle) and ask them to turn right and then stand very close together.
- ▶ Tell them to trust you and that when you tell them to sit they should sit even though there are no chairs.
- ▶ They should not squat, but sit normally.
- ▶ Tell them altogether ... sit!
- ▶ If they all trust, then they will all sit and be sitting on the knees of the person behind.
- ▶ If this does not work, point out that the group did not trust and so they took (untrusting) precautions of their own which took away from the trust the other people had.
- ▶ Discuss that these activities will not build trust by themselves, that they are only to make people aware of trust.

AND

Activity 3

- ▶ Form the participants into small groups.
- ▶ Ask each group to think of people (or groups) that they do not trust. Ask them to discuss why they do not trust them. (Is it fear or because they do not know them, or has the person broken trust?)
- ▶ Ask them to discuss how they can regain or develop their trust in the other person or group. What do they have to do to begin trusting?
- ▶ List the recommendations on the board or flip chart.
- ▶ Discuss with the large group the concept that trust is a necessary prerequisite for peace and that somebody has to start trusting the other, and it should be the peacemaker.

Teaching point

Trust is a necessary prerequisite to further work in peace education. Focus on the necessity of trust even if people have failed before, as without trust there can

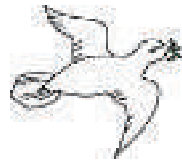

Communication (active listening)

60 minutes

Instructions

- ▶ Explain to the participants that communication is a necessary part of striving for peace.
- ▶ The first part of communication is to listen.
- ▶ We all think that we listen, but most of us are really very bad listeners and, because of this, we pass on misinformation, not because we are malicious but because we think we have listened and are passing on the correct information.

Activity 1

- ▶ Send three people out of the room and then tell the group that you are going to tell a story to the first person who is to listen and the tell it to the second person who will tell it to the third person, who will tell it to you.
- ▶ The group is to listen carefully to the story and see how it changes from person to person.

Tell a story something like this. *[The story should be fairly complex and with lots of irrelevant detail.]*

One day I went to the market and I was going to buy some tomatoes from a stall, I saw some young boys near the stall. They looked like street children and I thought they were waiting for an opportunity to steal something from the stall. Then I saw two or three strong young men coming towards the stall. I thought they were armed with sticks or maybe guns and I was afraid and thought perhaps I should run away. Then the stall keeper started to shout that there was a thief and the boys ran away. Then an old lady started to cry and dropped her shopping and all her things spilled on the ground. I ran to help her and found that she had taken some soap to look at and the stall keeper thought it had been stolen. I helped the old lady to pick up her things and explain to the stall keeper that she was not a thief.



- ▶ When the three people have retold the story ask the group what was the difference between the first story and the final story.

Discussion

- ▶ Were any of the stories accurate?
- ▶ What changed?
- ▶ Did anybody add things to the story?
- ▶ Did events or characters change in the story?
- ▶ What does this tell us about the way we listen?
- ▶ Ask participants if they have observed this distortion happening in their own lives.
- ▶ Ask participants what impact this faulty listening can have on the way we communicate?
- ▶ Does it lead to misinformation and miscommunication?
- ▶ Ask what other elements lead to misinformation and miscommunication.

Explain that generally people will try to make sense of what they hear.

If what they hear does not make sense to them they will shape the story according to their own experiences and expectations so that it makes sense.

This is also a bias because the story is shaped by the listener's experiences and expectations.

OR

Activity 2

- ▶ Do a 'poor listening' role-play with a volunteer.
- ▶ Exhibit all the poor listening characteristics while the volunteer tells you a story. [*Yawn, be distracted, interrupt the speaker to do other things, don't make eye contact, etc.*].
- ▶ Ask the group to list all the things you did wrong. [*This is often quite hard, but it will help the trust when they realize they are free to speak 'against' you without retaliation.*]
- ▶ Repeat the exercise, this time displaying all the active listening skills. [*Make eye contact, look and be interested, clarify information, ask questions, give summaries, ask for feedback.*]
- ▶ Ask the group to list what you did correctly.
- ▶ Summarize these as the active listening rules and then pass out the handout.

[Appendix 2]

OR

Activity 3

- ▶ Divide the participants into groups of three.
- ▶ Ask one of the group to be the speaker and another to be a listener.
- ▶ The third person should be the observer to see that the speaker and the listener communicate. The speaker should speak for a minute while the listener listens without interruption. Then the listener can summarize, ask for clarification and should then report back to the speaker. The observer checks that the information is correct and that the listener has displayed good listening skills.
- ▶ Then the people in the group should swap roles. Repeat until everybody has had a turn at being listener, speaker and observer.
- ▶ Ask the groups what they learned from the exercise.
- ▶ Give the handout Active Listening Skills [Appendix 2].

Be sure to move around the groups yourself and look for specific good listening skills yourself. Often people will accept whatever their colleagues do; it is important to see and praise the specific good skills that are utilized.

Do not accept the 'observer' saying 'yes, everybody was fine'; ask for specifics.

Discussion

- ▶ Ask the participants when and to whom they should listen.
- ▶ Ask if it is important for everybody to be listened to. Does this include listening to women? Does it include children? Why or why not?
- ▶ Ask what the difference is between listening and hearing.
- ▶ Point out that being listened to is a fundamental human right, not just for adults but also for children.
- ▶ Ask the participants to think about times when they have heard but not listened. *[A good example is often the religious leader - preacher or iman- people hear and they think they are listening, but afterwards they cannot tell you what was in the sermon.]*
- ▶ Ask what they think they should do from now on, not just in the course but also in their ordinary lives.

Teaching point

Ensure that the listening skills are well understood, (not necessarily well presented yet) and watch for faulty listening during the course. Be very aware of your own listening skills (or lack of them).

SESSION 4

Communication and miscommunication

45 minutes

Discussion

- ▶ Discuss with the participants that many of the attributes associated with Peace Education are elements of communication.
- ▶ Ask how miscommunication occurs.
- ▶ Open communication where people are honest, where they listen and where they try to understand the other person's point of view is the cornerstone to peace.
- ▶ This sort of communication can only happen when both sides in the communication are willing to try.
- ▶ Sometimes communication is based on what we assume about other people.
- ▶ This can be the result of the other person's body language, or their race, their level of education, their religion, their culture, their age, their sex. Not surprisingly, sometimes this type of communication is very faulty and can lead to misunderstandings and resentment.

If the participants said 'miscommunication' is one of the causes of conflict, refer to it here.

Miscommunication is usually a combination of not listening and making assumptions.

The 'miscommunication cycle' demonstrates this pattern of behaviour.

Miscommunication Cycle

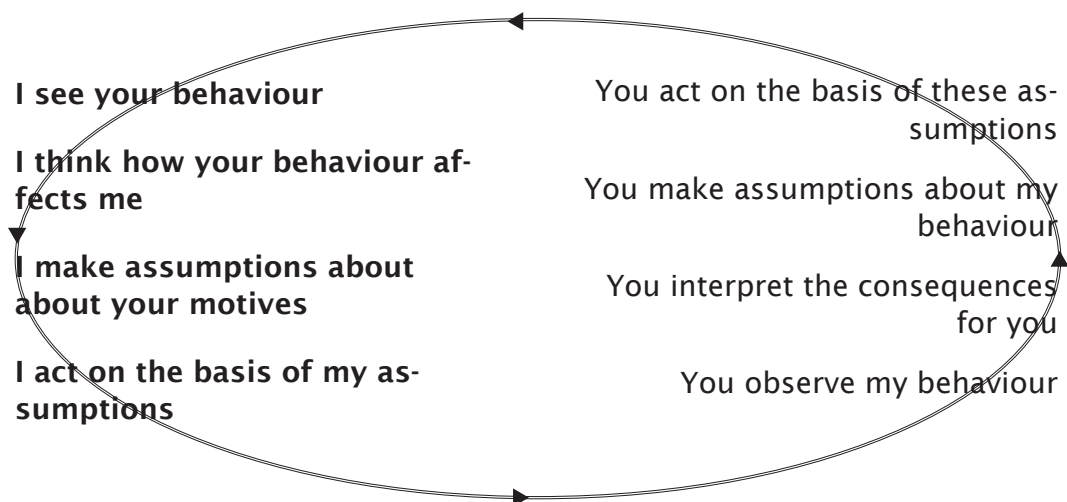

Activity 1

Ask two volunteers to play out a small drama to illustrate the miscommunication cycle.

Person A (give a local name): 'I need some help from my old friend ...' (give a local name, this is person B). 'Hmmm, he doesn't look very happy today. Perhaps I'll wait for a better time to ask him my favour.'

Person B: 'Look there is my friend... What he walks by without even greeting me. Obviously he is too proud to remember to speak to his old friends. See if I ever speak to him again.'

Person A: 'See now he refuses to speak. What is he trying to prove? Well, I will just avoid him from now on.'

Discussion

- ▶ Ask the participants if this cycle seems familiar.
- ▶ Ask if they have seen this and what misunderstandings arise as a result.
- ▶ Ask if they have solutions to the problems raised by this cycle.
- ▶ Discuss where the cycle can be broken by true communication. [*Before the assumptions are acted upon*]
- ▶ If the response is simply 'better communication', then continue with the next section; if there are a variety of responses, list them on the flip chart and allow discussion of the solutions.

Many conflicts arise because there is one-way communication. (e.g. dictatorships, gossip). This is unfortunate when we consider that much of the communication in society is one way. The next Activity is to see if one-way communication is effective or not.

Teaching point

Miscommunication often occurs without the people involved realizing it. Ensure that the participants really understand this miscommunication cycle and look for (and point out) when miscommunication occurs during discussion in the course.

One-way and two-way communication

60 minutes

Activity 1

- ▶ Divide the participants into groups of two.
- ▶ Give one of each pair a bag with an object inside. The participants are not allowed to look in the bag, but rather one puts a hand in the bag, feels the object and describes it to the partner.
- ▶ The second partner draws what the first partner describes.
- ▶ The second partner is not allowed to ask any questions.
- ▶ After five minutes, ask those who were drawing to show their drawings; at the same time, let their partners remove the objects from the bag.
- ▶ Discuss the shortcomings of one-way communication.

OR

Activity 2

- ▶ Take two of the group out of the room. Show them the picture of the geometric shapes. [Appendix 3]
- ▶ Invite one of them back inside with a copy of the picture. She/he is not to show it to anybody.
- ▶ Choose two volunteers from the participants. One is to go to the flip chart/board and the other out of the room (not with the first person.).
- ▶ The participant with the drawing (the instructor) gives instructions to the artist (the second participant) so that the artist can draw what has been described. The instructor should just give the instructions and the artist cannot ask any questions.
- ▶ The instructor stands behind the flip chart so as not to see it.
- ▶ The second instructor is brought in and given the copy of the geometric drawing. She/he is not to show it to anyone.
- ▶ The second artist is brought in. The instructor can explain and discuss with the artist as much as they like to get the best possible picture (one that looks as close as possible to the original). This time the instructor can watch what the artist is doing and make comment on it, and the artist can ask questions. (The artist cannot see the picture.)
- ▶ Discuss with the participants which drawing is better and why.
- ▶ Discuss and list the advantages of two-way communication.

OR

Activity 3

- ▶ Ask the participants to work in pairs.
- ▶ One in each pair draws a picture. They are not to show this picture to anyone.
- ▶ The pair sits back to back and the first partner describes the picture to his/her partner, without the latter seeing the picture and without being able to ask any questions.
- ▶ The second partner draws what the first partner has described (but on a different sheet of paper to where they have their own drawing).
- ▶ Do the exercise a second time, but this time the two partners should sit side by side so that the one describing can see what is being drawn and the one drawing is allowed to ask questions. But the second partner's picture should still not be shown.
- ▶ Compare the two drawings and discuss the advantages and disadvantages of one-way and two-way communication.

Often people will accept any drawing from their friend. Impress upon the group that the drawing must be as accurate as possible and the second time the exercise is done the instructor should do everything (except show the picture) to make sure that the drawing is as close as possible to the original.

Instructions

- ▶ Draw the matrix on the board or flip chart.
- ▶ Ask the group what are the advantages of one-way communication. Fill these in as they are suggested.
- ▶ Ask the group what are the disadvantages of one-way communication. Fill these in on the chart.
- ▶ Ask the advantages of two-way communication and then the disadvantages.
- ▶ Fill these in on the chart.
- ▶ Allow as much discussion as the participants need to have.
- ▶ Reiterate that communication is the single most important element of peacemaking and that everybody should be very clear about this importance.
- ▶ Ensure that the discussion is limited to communication; if it moves to emotions or problem-solving, explain that these issues will be raised later in the course.

	one-way	two-way
advantage		
disadvantage		

Teaching point

There should be many more advantages to two-way than to one-way communication. The point needs to be made that only through two-way communication can real problem-solving occur. Giving orders without ensuring understanding and allowing for internalization will result in rote memorization and manipulation.

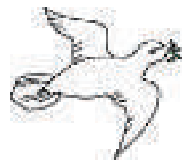

Perceptions

45 minutes

Instructions

- ▶ Use one of the perceptions cards [Appendix 4] and walk around the participants showing the picture. Turn it each way around so that people can see it upside down and sideways [*in case they see something you have not seen*].
- ▶ Ask what people see.
- ▶ Make sure every participant has a chance to see the picture clearly and closely.
- ▶ Allow the discussion of what they say the picture is but point out that people were asked how many/what they *saw*. (i.e., it is their own opinion).

Discussion

- ▶ Explain that perceptions are a way of viewing things and that, by themselves, they are neither right nor wrong: they are a form of opinion. When a perception is regarded as a truth, however, there may be problems.
- ▶ Perceptions lend a bias to what we see and judge, and if we pass on our perceptions as fact when we communicate, our perceptions may become miscommunication, stereotypes or discrimination.
- ▶ Ask on what basis the perceptions are made. How many examples do people need to see before they make a judgement?
- ▶ Ask what are the perceptions about: particular national/ethnic groups, women, men, particular religious groups, UNHCR/NGO staff, etc.
- ▶ Ask what other information the participants have about those groups (i.e., information about why people may act as they do).
- ▶ Ask how long it takes for these perceptions become stereotypes and what happens when they are stereotypes.
- ▶ How many perceptions held by the group related to religion or culture? Does this make them true?
- ▶ Ask for stereotypical judgements about the group to which you (the facilitator) belong. Insist that the participants think of less than flattering stereotypes. When given the stereotype, ask if you fit it.
- ▶ Ask then how a characteristic becomes a stereotype and what impact it has on the way the participants judge you.

Focus discussion

- ▶ Ask the participants what the perceptions are about girls in the cultural groups to which you belong?
- ▶ Ask if these perceptions are really true. Ask for examples where the perceptions are untrue.
- ▶ Ask the group why girls have (for example) more chores than boys? What are the perceptions behind these behaviours?
- ▶ Do girls have the same rights as boys? Why or why not?
- ▶ What are the perceptions about girls in school? Do girls do as well in school as boys? [Point out that the teachers will also have perceptions as to how girls should behave in class.]
- ▶ Are girls 'invisible' or considered possessions? What are the perceptions behind these behaviours and what are the consequences?

Point out that children will live up to expectations of them, whether these are good or bad.

Tell this story. A man put some jumping fleas in a jar and put the lid on tight. Every day the fleas jumped and hit themselves on the lid. After some time they learned to jump only as high as the jar and so not hit themselves. When they were let out of the jar, they never jumped higher than the jar.

What does this tell us about perceptions and expectations of ourselves?

Teaching point

Perceptions have a close link to stereotypes and are developed by use of language (both verbal and non-verbal) as well as accentuating the differences between groups. The way the world is viewed depends very much on willingness to be open-minded. In the Peace Education Programme it is important to remind participants about being open-minded

SESSION 5

Bias

90 minutes

Discussion

- ▶ Ask the participants what they think the word 'bias' means.
- ▶ Bias is when you slant the truth or the facts to give an impression that is not a lie but is not quite the truth. (Or at least not the whole truth).
- ▶ Bias is also the things that we do not say. If we do not like someone, then we do not tell others of their good qualities; only their bad qualities.
- ▶ Stand upright and then lean to one side and then the other. Point out that bias is a leaning towards one side of an issue and may be done through language - words that we use - or through our actions.



Activity 1

- ▶ Ask a volunteer to describe his/her home community and life there.
- ▶ If appropriate, write the essential points of the description on the board.
- ▶ Describe the situation yourself, making the bias obvious: e.g. a refugee camp has advantages such as free accommodation, free food, free medical facilities, free education, police protection, an opportunity to meet new people, etc.
- ▶ Ask the participants which description is true. Point out that you have not said anything untrue.
- ▶ Allow as much discussion as necessary to develop the idea of bias being a selection of certain facts to 'slant' a story or an argument in a particular way. *[Telling part of the truth.]*
- ▶ Help the participants to define the difference between 'objective' statements and 'subjective' statements. (Subjective statements are those given to bias; they are opinions or facts with an opinion 'built in'. Objective statements are those agreed on by neutral observers or observers from both sides as definitive facts).

OR

Activity 2

- ▶ Ask participants to think of names that are commonly used to describe people: peasants, professor, thieves, bandits, freedom fighters, warlords, collaborator, traitor, powerful, emotional, sensitive, strong, modest, submissive, etc.
- ▶ Ask participants to draw a line down the centre of their page. Ask them to put the words that they think are positive on the left-hand side and the ones that they think are negative on the right-hand side.
- ▶ Ask why they think these words are positive or negative.
- ▶ Choose some of the words that you feel are attached to a particular understanding: e.g. 'powerful'. Ask if this is a positive or negative word. Ask them to describe a powerful person. Assuming this person is male, ask if a woman who displayed these same characteristics would be called powerful. If not, how would she be described?
- ▶ Point out that the meaning of certain words, which carry an emotional meaning, is also bias.

This Activity can also be done by writing the words on slips of paper and giving them to every second participant. Draw a line down the centre of the floor and ask the people with the slips to discuss with their neighbour on which side of the line it should go. People are then asked to explain why they have put it in a particular place. The discussion should be open to all the participants.

AND

Activity 3

- ▶ Choose three or four statements from the following (or write similar statements according to the people in the group. It is important that the statements should imply 'all'.):
 - ▶ Somalis are an intellectual people.
 - ▶ Christians are the true believers.
 - ▶ Mandingos are good at business
 - ▶ Sierra Leoneans are always fighting.
 - ▶ Muslims are the true believers.
 - ▶ Sudanese are warriors.
 - ▶ Rwandans think they are superior.
 - ▶ White people are superior.

Discussion

- ▶ Ask participants if they agree or disagree with the statements. Ask why they agree or disagree.
- ▶ Point out that these statements have an implied 'all' in them. (e.g. 'all white people think they are superior'). Any statement that implies 'all' or 'none' is a statement of bias.
- ▶ Point out that the statements that people agree with have just as much bias as those statements with which they disagree. Therefore when they agree or make statements like these they are being biased.
- ▶ Ask if any of these statements is absolutely true.
- ▶ Ask if anybody can think of a stupid Somali, a Christian or a Muslim who is not a true believer, a Sudanese who does not want to fight, a humble Rwandan or a humble white person, etc.
- ▶ Ask what words are used to describe such people. Are these words also biased?

OR

Activity 4

Write the words in the left hand list on the board:

Man	Woman
warrior	
hero	
strong	
intelligent	
brave	
wise	
caring	
provider	
farmer	
pastoralist	
blacksmith	
aggressive	
primitive	

Use words that are commonly used to denote a particular bias. Be very aware that you also have bias and that this bias will be evident to the participants.

Ask participants what these words signify. Are they positive or negative?
Put a '+' if they are positive and a '-' if they are negative.
Then start the list for 'Woman'

Discussion

- ▶ Ask participants if you moved all the other words to the new list would they still be positive or negative?
- ▶ Do their meanings change if they refer to the opposite sex?
- ▶ If they change then they are words that carry bias. If they have a negative meaning (emotion) and are used in a derogatory way (e.g. blacksmith, peasant, primitive), then they carry bias.

AND

Activity 5

- ▶ Ask participants to explain what loyalty means. Ask if this is a good thing or a bad thing?
- ▶ Describe a situation of mediation where the mediator is loyal to the person from his/her own clan or tribe, and so listens with sympathy to that person but with suspicion to the other person.
- ▶ Ask if they are displaying loyalty? Ask if this loyalty is positive or negative?
- ▶ Tell this story (this came from a role play in Hagadera, Dadaab). [*Substitute tribe for clan if appropriate.*]

A man wanted to sell a goat. The broker organized a sale where both the seller and the buyer agreed on the price. Before the sale took place, a man from the seller's clan wanted to buy the goat but did not want to pay as much as the other buyer had offered. The broker was informed, who then told the first buyer that the sale would not happen. The buyer wanted to know why. The broker came from a different clan to both the buyer and the seller but his clan was 'friendly' to the seller's clan. The seller accepted the lesser amount of money and sold to the man from his own clan.

<p>Discussion</p> <ul style="list-style-type: none">▶ Ask the participants if there is bias here. Ask who was biased? Allow participants to discuss why there may have been bias and what are the effects of this bias.▶ Ask:▶ Will the first buyer trust the people from the seller's clan again?▶ Will the first buyer trust the broker again?▶ What happens if the two 'friendly' clans fight in the future? Will the loyalty shown by the broker and the seller to people from their own clan be greater than the new dispute?

AND

Activity 6

- ▶ Ask the participants to list 'value-laden' words that they hear (and use). Remind them of the words discussed in the trust session.
- ▶ Ask the participants to define what the words mean in everyday use. e.g. for many English speakers the word 'collaborator' has a negative connotation but to collaborate means to talk with someone and to work together with them. If it is appropriate, discuss two versions of a freedom struggle. The bias is evident in everything that has been reported by both sides in relation to a group of fighters. Compare this with the official or dictionary version of the word.
- ▶ Allow the participants to discuss bias as they see it in their lives but point out that they too are subject to bias.
- ▶ Ask if anybody has recognized bias in any of the discussion that has taken place so far. (e.g., have women or children been ignored? Have we thought about the elderly or the disabled?)

Teaching point

Bias is reflected in many things that we say. Check continuously throughout the course for elements of bias in both the participants and yourself. (e.g., always ask 'Why do you think so?')

Stereotypes, prejudice and discrimination

60 minutes

Instructions

- ▶ Ask the participants what the consequences are of bias.
- ▶ Draw this diagram on the board.

Bias	Stereotype	Prejudice	Discrimination
A particular point of view	When this point of view is applied to all people	When the point of view makes you act in a particular way	When your actions make sure that resources are not given to the group against whom you are prejudiced

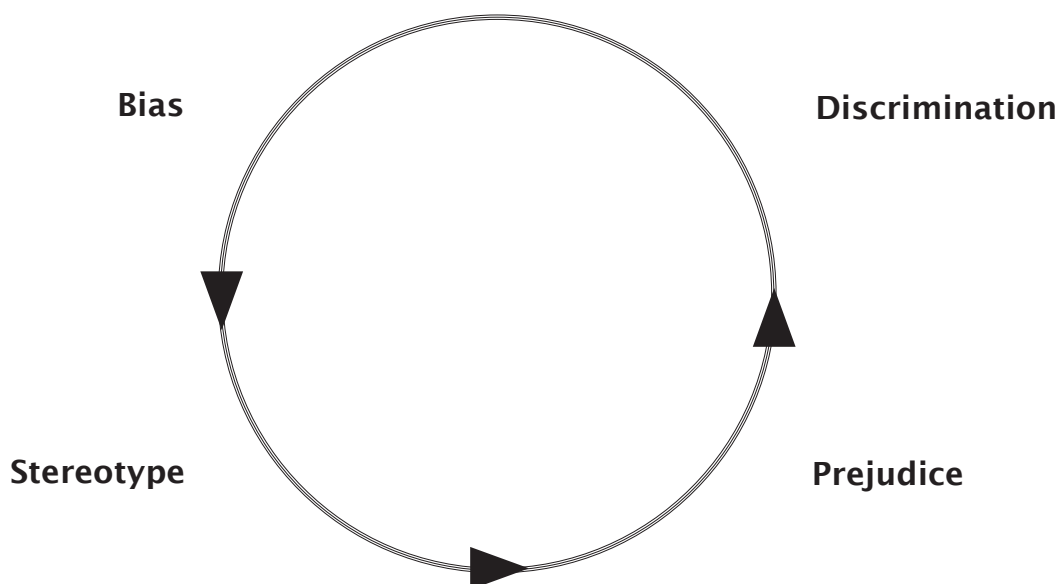

Discussion

- ▶ Ask the participants if they have seen this occurring in their communities.
- ▶ Ask what happens at the top of the circle. [*Very often people react violently to the discrimination.*]
- ▶ Ask when the cycle can be broken.
- ▶ Discuss with participants why the cycle should be broken and what they can do to break the cycle in their own lives.

Activity 1

- ▶ Group the participants into small groups and ask them to develop a role-play about gender inequity, HIV/AIDS, religion or race that demonstrates a bias turning into stereotypes and prejudice.
- ▶ Ask two or three groups to perform their role-plays and allow open discussion on the stereotypes that occur.
- ▶ Ask the remainder of the groups to think how they can break the link between bias and stereotypes or between stereotypes and prejudice.
- ▶ Without allowing any discussion amongst these groups ask them to perform their role-plays.
- ▶ Ask the rest of the participants how effective the groups were at changing their stereotypes and breaking them.

Discussion

- ▶ While bias is an opinion, as soon as that opinion is translated into an action, it is a cause of conflict.
- ▶ There are various forms of discrimination; some of them are informal (held by people without affecting everybody); some of formalized and greatly affect the society e.g. women are considered inferior to men. Because of this, women cannot hold possessions.
- ▶ After the genocide in Rwanda when people returned to their homes many women who were widowed in the war could not reclaim the land of their families, even though they had children to raise and they were good farmers. Eventually the law was changed so that women could inherit the land, but this was done because the women got together and demanded their rights.
- ▶ What formalized discrimination is there in your society, either traditional or through the modern law?
- ▶ What are the results of this discrimination?
- ▶ Allow open discussion on these points.

Remember your questioning skills; the point that you want them to come to is that stereotypes are deeply hidden in our hearts and it takes courage to break them openly.

Very often our language reveals the stereotypes and you will also be affected, so be very careful

A society is poorer when a part of the society is discriminated against. If you do not let girls learn, then half the brainpower of the community is lost. Can any community in this modern age afford to lose half its mental resources?

Focus discussion

- ▶ Girls are often discriminated against when they behave differently to expectations. These expectations are often called 'culture' but usually they are not culture but habit. E.g. girls are pestered after school by 'sugar daddies' who want to have sex with them. The girls face several problems relating to culture (and the 'sugar daddies' take advantage of this).
- ▶ Respect for elders is a cultural value, so the girls feel that they should obey these older men.
- ▶ Need for money for the family: Support for the family is a cultural value, but most parents do not want their daughters to prostitute themselves for the family (often they do not call it this, but getting money in return for sexual favours is prostitution).
- ▶ Family: Girls are often perceived as possessions and because of the 'extended family' in many cultures, girls feel that they have no choice if the man is an 'uncle'.
- ▶ Submission: Girls (in particular) are supposed to be obedient and to serve in many cultures, therefore the girls are not assertive and cannot say 'no' when being sexually harassed. Initially they may not even see it as sexual harassment.
- ▶ Discuss these issues in the context of the group and ask the participants whom the culture favours and who are discriminated against.

In many cultures rape is treated as a crime committed by the victim. In some cultures this is extreme where the woman is punished for adultery even when this was an unwanted rape.

In other cultures, the woman is treated as a criminal in a court of law and unlike other crimes she has to prove that she (as the victim) is innocent.

This level of discrimination is deeply embedded in the culture and laws of the countries.

Ask participants:

How can these be overcome (should they be overcome?) in the interests of social justice and therefore true peace.

OR

Focus discussion

People often discriminate against people who are HIV+. Why is this so?

Is the discrimination because of the disease or how it is acquired? Think about the disease itself. It is a disease like any other - you can get tuberculosis from people who already have it - but there is not the same discrimination. Why?

What about blame? Who is blamed in a situation where a couple discover that one is HIV+?

What are the elements of culture that lead to this discrimination? Are they really valid?

What if the woman becomes HIV+ as a result of the rape?

Discuss the real causes of discrimination of people who are HIV+

Look at how the stereotype linked to HIV/AIDS is linked to fear. How can this be overcome?

What will this group do to help overcome the bias, stereotypes and discrimination of people in the community who are HIV+?

You need to be very aware of your own biases here and your own knowledge level concerning HIV/AIDS. Keep the discussion open and objective.

The discrimination of people who are HIV+ often has more to do with judging people's sexual behaviour than it has to do with the disease. Sexuality is closely linked to values in religion and culture; if necessary point this out.

Teaching point

Discrimination is often justified by apportioning blame. Remind the participants that blame is the first thing that must be discarded if we are to have peace. Blame is destructive, not constructive, and it allows us to avoid taking responsibility for finding solutions to problems.

SESSION 6

Emotions

45 minutes

Discussion

- ▶ The way that we feel about people or situations (our emotions) can make us very open or close us from any real communication with others. Nothing in peace education can work if people do not want them to work. Everything requires goodwill and this is the most difficult part of peace education.
- ▶ Very often we do not recognize our emotions (in many cultures we are prevented from displaying certain emotions and from recognizing what we feel). First we need to recognize the emotion and then we need to see how it affects our behaviour. In this way we can see when our emotions are destructive and we can learn how to manage them.
- ▶ Our emotions very often lead us to make generalizations, to bias, to create stereotypes and to discrimination. Why?

Activity 1

- ▶ Ask the participants to form small groups and develop role-plays that have an emotional aspect.
- ▶ Allow each group to show their role-play and then ask the characters how they felt at various points in the role-play (e.g., How did you feel when you were not allowed inside? How did you feel when you refused to help the refugee?)

Discussion

- ▶ Ask the participants to stay 'in role' until after the discussion.
- ▶ Discuss the emotions that the players say they had and how these emotions affected their actions.
- ▶ Discuss whether this happens in real life and how this should be dealt with.
- ▶ What actions should a peacemaker have when faced with somebody who is allowing their emotions to rule the way they act?

OR

Activity 2

- ▶ Write a series of emotions on separate strips of paper. e.g. joy, bewilderment, sadness, anger, frustration, jealousy, hatred, love.
- ▶ Put all the strips into a hat (or any container) and then ask each participant to draw out one strip.
- ▶ Ask volunteers to come to the front of the group and act out the emotion they have chosen.
- ▶ The remainder of the group have one minute to try to guess what emotion has been played out.
- ▶ Keep going around the room until everyone has had a turn.

If you have a large group, you may want half of the participants to work on the role-plays and the other half to act out the emotions. This will enable you to still have the benefit of the 'teaching moment', which occurs so often in the role-plays, but it adds variety and a change of pace.

Empathy

60 minutes

Discussion

- ▶ Empathy is the ability to feel things from the other person's point of view.
- ▶ Ask the participants to think of phrases, proverbs and sayings that exemplify empathy. (e.g., walk a mile in my shoes).
- ▶ List some of these and discuss what they mean and why empathy is important.
- ▶ Empathy means understanding (not necessarily agreeing with) why an individual acts in a particular way. If you truly put yourself in the position of the other, then it is often possible to see why people act the way they do. Once that is understood, it is easier to work with that person to find solutions to problems in which he/she is involved.

Activity 1

Tell one of these stories to the participants.

Story 1.

Two refugees (father and daughter) go to the office to ask for separate blankets. The officer agrees and goes to collect an extra blanket from the store. Here the officer is stopped by a senior officer, who asks what is happening. The senior officer is angry with the officer and says that the blanket cannot be given. The senior officer then says that he will interview the refugees to see if they are genuine.

At the interview the senior officer separates the refugees and interviews them one by one. He tells the father that it is not possible to break the rules for one family because then everybody will want separate blankets. When he interviews the daughter, his first remark is that she is too fat to be a refugee and that probably she is a recycler. He says that at her age she ought to be married anyway and not living with her father. If she were to be married the dowry would be able to buy blankets enough for her father.

The senior officer then calls for the officer and tells him to bring a blanket from the store. He calls in both the father and the daughter and then tells the junior officer to cut the blanket in half and he gives half each to the daughter and the father.

Discussion

Ask the participants:

- ▶ Why do you think the refugees wanted separate blankets?
- ▶ Why do you think that the officer agreed?
- ▶ Why do you think the senior officer was angry?
- ▶ Why do you think the senior officer interviewed the refugees?
- ▶ Why do you think he said the things he did to them?
- ▶ Why do you think the senior officer brought the junior officer in to cut the blanket?
- ▶ Why do you think he wanted the blanket cut in half?
- ▶ How do you think the daughter felt? Why?
- ▶ How do you think the father felt? Why?
- ▶ How do you think the junior officer felt? Why?

OR

Story 2.

There is a widow with five children, all very young. She has no one to help her with the chores. She has to collect the water and food herself, and do all the cleaning and cooking. She wants the children to go to school, but there is no money for clothes and sometimes the children have to stay inside because there are not enough clothes for all of them to be dressed.

One day, just after she has brought back two heavy jerrycans of water, two of the children begin to fight. One is hurt and starts to scream and cry. The other one runs away. As he is running, he knocks one jerry can and it spills all the water.

The mother catches the child and hits him until he is screaming and crying but even then she feels such anger that she cannot stop. A neighbour comes to see what all the noise is about and stops the woman from hitting her child.

Discussion

- ▶ Why do you think that the woman acted the way she did?
- ▶ Why do you think the children fought?
- ▶ Why do you think one child ran away?
- ▶ Do you think that the child meant to spill the water?
- ▶ Do you think that the mother was hitting the child for spilling the water, for fighting, for hurting his brother? Why?
- ▶ What do you think the mother felt when she couldn't stop hitting the child?
- ▶ Why do you think she felt that way?
- ▶ Can you feel what the mother felt?

OR

Story 3.

A young boy came from a very poor family. He knew that there was not enough money for him to go to school even though he wanted to learn and he did not want to be like his father.

One day, soldiers came to his village. The soldiers were tall and strong, and wore uniforms and carried guns. They were powerful men who took food when they wanted it and told everybody in the village what to do, and even the elders obeyed them.

The boy wanted to be like them. He followed the soldiers everywhere they went. He carried their food for them and their backpacks. One day the soldiers said they were leaving to go and fight past the next village. The boy decided to go with them and become a soldier.

Discussion

- ▶ Why do you think the boy did not want to be like his father?
- ▶ Do you think the boy admired the soldiers? Why?
- ▶ Why do you think the boy followed the soldiers and did things for them?
- ▶ What do you think the boy felt when he saw the soldiers taking whatever they wanted?
- ▶ Why do you think the boy decided to become a soldier?
- ▶ When child soldiers return, it is important that the community has empathy as the children are just as much victims of the conflict as any other victims.

OR

Story 4.

A young girl attends school and works hard. Her parents encourage her to go to school because they want her to be educated for when they return to their home. They feel that it is important for her to have an education as the world is changing very quickly and she will be able to help rebuild their country.

Next door there is another girl. Her parents do not allow her to go to school, as they fear that she will learn things that are foreign to their culture and will not be able to find a husband. They want to be able to go home when there is peace in their country and rebuild their lives. The girl wants to go to school with her friend and is unhappy that she has chores all day that prevent her from going to school.

Focus discussion

- ▶ Why do you think that the first parents are anxious for their daughter to have an education?
- ▶ Do you think that these parents are worried that their daughter will not be able to find a husband?
- ▶ Both sets of parents want to be able to go home and rebuild their country. Why do you think their attitudes are so different?
- ▶ Why do you think the second parents are worried that their daughter may not find a husband?
- ▶ Why do you think they are afraid that education may ruin their daughter?
- ▶ Why do you think that the second girl has to do chores all day?
- ▶ Do you think that the first girl also has chores to do?
- ▶ Do you think that the second girl wants an education or does she just want to go to school? Why?

Instructions

Ask other questions of the participants so that they truly start to put themselves in the place of the people in the stories.

When participants can really put themselves in the place of the others, explain that this is empathy.

Empathy is understanding why people act in a certain way, by trying to see things from the other person's point of view and understanding what motivates people to act in these ways. This makes it easier to solve problems because the attitudes and motivations of people are taken into account when the solutions are suggested, so nobody loses dignity and a 'win/win' solution can be real. *[Explain to the participants that you will deal with 'win/win' solutions when you do the section on problem-solving later in the course.]*

AND

Activity 2

- ▶ Ask the participants to work in pairs.
- ▶ Each pair should design a role play for two people where there is a problem or argument.
- ▶ Allow the groups time to 'work through' their role-play and explain that you want them to 'practise' their role-play.
- ▶ Ask some participants to perform their role-play but stop the role-play at the point of conflict.
- ▶ Ask each person how he/she feels: frustrated, angry, hurt, proud?
- ▶ Then ask the two actors to swap roles and do the role-play again up to the same point.

Stop it again and ask how they feel.

- ▶ When the role-plays have been done a second time, ask if the participants felt differently once they knew what it felt like to be 'on the other side'. [*Don't be distressed if the participants 'took their revenge', but point out that this is what they have done.*]
- ▶ Discuss that this 'knowing how the other side feels' is the beginning of empathy.
- ▶ Ask the participants how they feel that it would alter how they work with people to solve problems if they understand how the other person feels.
- ▶ Does it help them modify their behaviour? If not, why not? If they do modify their behaviour, in what way has it changed?
- ▶ Refer back to the role-plays on emotions and ask particular individuals why they acted as they did and how they understood that this was the way the characters they were playing would respond.

Discussion

Discuss the concept that acting is a type of empathy. Empathy as a part of being a peacemaker is taking into account why other people act as they do and therefore not responding to the emotions or behaviour of the other person if these emotions affect their behaviour or judgement.

Instead, by understanding what prompts those emotions and behaviours, and acknowledging them, it may be easier to respond to the needs of the other person rather than to the position that the other person has taken. This is called separating the person from the problem.

This will be dealt with again when there is a session on problem-solving.

Teaching point

As the facilitator it is important for you to display empathy to the group. Use positive body language; stand as close to the participants as is culturally appropriate; look at those who are speaking and use your peripheral vision to ensure that you are including the whole group. As far as possible, make sure that you include all the group in your eye contact and that you listen for the comments that are made so that you can use the teaching points made by participants.

Empathy is a value rather than a skill. It has elements of skills (such as listening and observation) but it requires an 'open-heartedness' and a willingness to like the group with which you are working.

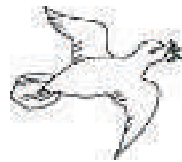

Cooperation

45 minutes

Instructions

- ▶ Ask the participants why they think cooperation is important.
- ▶ Try to write one word (or one phrase) summaries of each participant's view on the board or flip chart.
- ▶ Ask the group:

Why is cooperation important?

With whom do you cooperate?

Who do you not cooperate with?

Why?

Does cooperation need trust?

Is the lack of trust reasonable?

Activity 1

- ▶ Allow the group to discuss these questions and then introduce the 'Human Knot' as a game to illustrate some of the things they have discussed.
- ▶ Ask for a volunteer to wait outside. (Make sure that the volunteer is a confident person.)
- ▶ Ask the group to stand in a circle and hold hands AND NOT LET GO OF EACH OTHER'S HANDS NO MATTER WHAT.
- ▶ Help the group to make a knot by going under people's arms, over arms, etc. When the group looks tangled, call in the volunteer and ask that person if they can untangle the knot.
- ▶ Explain that the group will co-operate and do as they are asked but that they cannot let go hands.
- ▶ Time the exercise to see how long it takes to untangle the knot.
- ▶ Do the exercise again, but this time with everybody part of the circle. When the knot is completely tangled, tell the participants that this time there is nobody to help and that they need to untie the knot for themselves.
- ▶ Time how long this takes.

Discussion

- ▶ Explain that this is like conflict; each step to a conflict is only small, but all the steps together make a conflict. Then, to try to solve the conflict, everybody must cooperate. If we cooperate with an outsider to help us, it may take a long time. (This may be necessary if our emotions overpower our skills.) But to solve a conflict quickly, we need to cooperate with each other.
- ▶ Ask if it was easier when there were several people working on it together.
- ▶ Allow free discussion on the need for cooperation and point out that, if everybody cooperates, things are solved more quickly and easily than if it is left for one person to try to solve.
- ▶ Ask what happens when only one person cooperates. Is it possible for an equal solution to be gained if there is only one person cooperating? What are the results of non-cooperation?
- ▶ Point out to the participants that when people do not cooperate it results in a win-lose situation and the solution usually has to be enforced by a third party who has power.
- ▶ Point out to the participants that cooperation takes a willingness to try, a willingness to see things from the other person's point of view and an understanding that we are all similar in many respects.

Focus discussion

Do we cooperate only with those people we consider our equals or our superiors?

What about women and girls? Do we cooperate with them? Why or why not?

According to the Universal Declaration of Human Rights, all people are to be considered equal. Does this mean we should cooperate equally with all people?

Is it possible to treat people equally and to ensure that they have equal rights without cooperating with them?

What does this mean in terms of food distribution? Who should get the most food in a family? Who does get the most food?

What about those who are sick? Does the type of illness make a difference as to how well people are looked after?

Do we (for example) look after those with malaria but not those who have a sexually transmitted disease? Why is this?

Between couples who are going to have sex, women often want to protect themselves against sexually transmitted diseases by getting the man to wear a condom. Should the man co-operate and wear a condom?

What does religion and culture have to say about sexually transmitted diseases?

People often say that their culture or religion says that girls and women should not be equal. Point out that culture changes and religion are invariably interpreted by men (who may have a bias). True equality does not mean 'sameness'; it means to have equivalent rights and responsibilities.

Breast-feeding women and growing children need more food than anybody else. This is often the opposite to what happens in many cultures. If participants say that men work harder and therefore deserve more food, point out that statistically women do more work in the world and that this will be looked at in more detail later in the course.

Point out that wearing a condom is a protection for the man as well. Be prepared to discuss this openly and remember that, if you appear embarrassed, the discussion will not be constructive.

Teaching point

Co-operation involves listening and emotional honesty to see when you are acting out of pride or stubbornness. Ensure that participants cooperate with each other in role-plays and other activities.

Be aware that you are also expected to co-operate with the group. This may include answering questions as they arise (remember to listen for the teaching point) and allowing a discussion that may be at a tangent from what you have prepared.

Remind the groups (when necessary) that allowing somebody else in the group to speak is also co-operation.



Assertiveness

60 minutes

Instructions

- ▶ Ask participants if they are familiar with the terms aggression, assertiveness and submission.
- ▶ Ask what the words mean to them. (Often assertiveness is described as being part way between aggression and submission.)
- ▶ It is more appropriate to view assertion as constructive behaviour (reasonable or useful) and to view both aggression and submission as destructive behaviours.
- ▶ Draw the diagram on the board or flip chart.

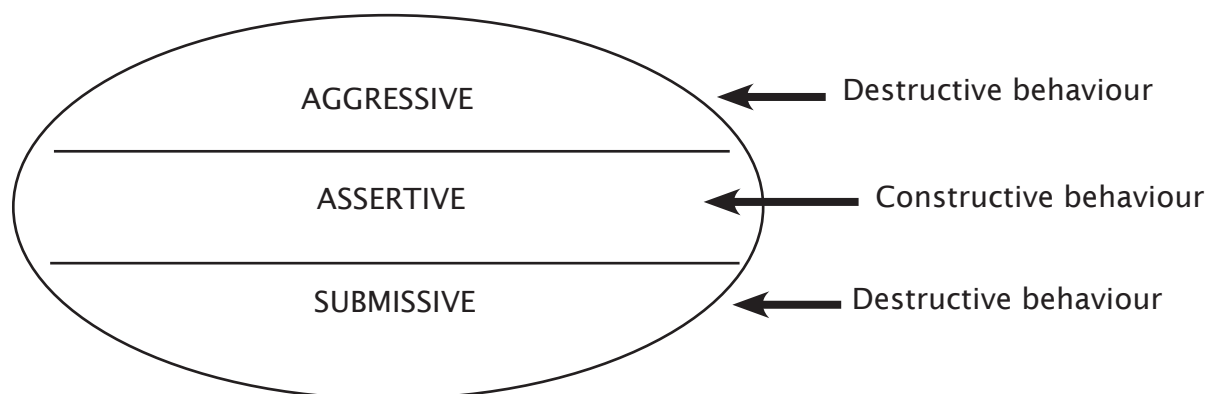

Discussion

- ▶ Ask participants why aggression and submission are considered dysfunctional behaviours.
- ▶ Discuss that aggressive people are often the cause of conflict, but that often submissive people become 'defensive-aggressive' and it is an abuse of human rights to expect people to be submissive because of age or status.
- ▶ Discuss with the participants that the effectiveness of a particular behaviour pattern may be short term or long term: short-term effectiveness may satisfy the emotions of the moment but will probably not resolve problems.
- ▶ Thus aggressive behaviour may enable someone to get what he/she wants in the short term, but it may arouse dislike, non-cooperation and perhaps revenge on the part of the other individual.
- ▶ Give out the handout and discuss the elements of each of the behaviours. *[Appendix 5]*

Aggressive is when a person:

- ▶ stands up for their own rights without caring for the rights of others
- ▶ makes sure that they are okay no matter what happens to others
- ▶ accuses and blames others
- ▶ denigrates other people's point of view ('you must be stupid')

Assertive is when a person:

- ▶ stands up for their own rights while acknowledging the rights of others
- ▶ respects themselves and the other person
- ▶ listens to what the other person is saying
- ▶ separates the problem and the person
- ▶ doesn't blame the other person
- ▶ expresses themselves clearly and honestly

Submissive is when a person:

- ▶ takes no action to assert their own rights
- ▶ puts others before self at their own expense
- ▶ gives in to what others want
- ▶ remains silent
- ▶ apologizes more than is needed.

Activity 1

Ask the participants to form small groups and then ask them to group the following statements under the headings of aggression, assertion or submission. They should discuss the statements fully and check against the definitions of aggression, assertiveness and submission.

'If you don't wear a condom, I cannot make love with you'

'I feel uncomfortable when you touch me like that'

'I think we should try to do this, but this is only my opinion'

'I feel frustrated when I talk to you but you don't listen'

'You're just being stupid when you talk like that'

'I need to think about what you have said before I make a decision'

'You go ahead to the party; I will stay behind and finish our work'

'But I want to go now, why we should all have to wait for **you?**'

'I bought you a drink; you owe it to me to love me now'

'You're afraid, everybody else says it will be okay; you must be just stupid'

'If you feel like that, that is your opinion, but I can't agree'.

Discussion

- ▶ Allow the groups to say why they grouped the statements as they did.
- ▶ Ask if they would feel differently if a young girl made the statement or a community leader, or a child to the parent or the parent to the child.
- ▶ Point out that assertiveness is never a lack of good manners; it is true respect for the other person's feelings and position as well as your own.

AND

Activity 2

- ▶ Give out the handout [Appendix 6] (or write it up on the board or flip chart) and work through this with the participants.
- ▶ Explain that to depersonalize the problem is to state the problem without emotion, not to blame the other person or to accuse them.
- ▶ The two people involved in solving a problem should be 'on one side of the table and the problem on the other side'.
- ▶ 'I feel' is a statement of your own feelings. It should not be an expression of those feelings (e.g. to say I feel angry should be said calmly rather than angrily).
- ▶ 'What do you think?' allows the other person to say what they think and also to show (perhaps) where they feel you have been wrong. It is important here NOT to respond to their anger or their assumptions.
- ▶ 'Would you be able to....?' should look at a variety of solutions to resolve the problem.
- ▶ Point out to the group that, when people are involved in a problem, it is very easy to respond to anger or sadness or emotional warmth and that this may result in dysfunctional behaviour, which in turn may make more problems in the future.

Focus discussion

Discuss the following scenario with the participants.

If a boy and a girl are in love and he wants to sleep with her, he may try to persuade her by telling her that everything will be all right, that everybody does it and that if she really loved him she would. It is difficult for the girl (if she loves him) to respond with appropriate assertiveness. Assuming that she feels she should not sleep with him, then she needs to be able to explain that she feels pressure because he keeps asking her and telling her it will be all right. She then needs to offer alternatives to sleeping with him (not seeing him, only seeing him in a group, waiting until they are married, waiting until they know each other better, etc.) She may also respond to the pressure by saying that she feels he does not really love her if he does not care about her feelings. If she responds aggressively - 'You must be stupid' - it is likely to provoke anger and pride; if she responds submissively she will agree but that agreement may well cause problems in the future.

APPROPRIATE ASSERTIVENESS

What you say	Principle of assertiveness
There is a problem about...	Depersonalize the problem; discuss the problem, not the people involved.
I feel...	No blame to the other person; the emphasis should be about how you feel not accusing the other person.
Because...	Say why you feel as you do; this requires emotional honesty and an ability to be objective about the problem.
What do you think?	Clarification of problem; this requires both sides to really listen to make sure that both sides really understand all the points of view.
Would you be able to...? Perhaps we could...	Presenting options; it is important look for constructive solutions (otherwise it is an accusation to the other person). This requires thought and work (which is perhaps why people don't do it very often).
Agree on a solution	Assertiveness takes into account the rights of the other person as well as your own rights. This does not mean what the other person necessarily claims as their rights; it means the right to be treated with respect and dignity.

OR

Activity 3

- ▶ Ask participants to form pairs. Each pair is to list as many alternatives as possible for girls to use when being assertive about saying 'no' when they don't want sex or when they want protected sex.
- ▶ Ask the pairs to think of all the situations where a girl might feel that she is being forced (by hunger, an older man, promises of money, feeling that she is in love, etc.)
- ▶ Share the responses from the pairs and discuss which ones they would feel comfortable about discussing with their own children.
- ▶ Discuss how we can get the message of safe sex across to youth when we do not feel comfortable about talking about some aspects.

Focus discussion

- ▶ It is important for girls to learn how to be assertive, especially in matters of sexual activity. Discuss this with the group.
- ▶ How do we teach our daughters and sisters to be assertive so that men do not take advantage of them?
- ▶ Is it important for our girl children to have enough self-esteem so that they value themselves and their bodies more than a soda or some food or the danger of an argument in the community? How do we build the girls' self-esteem?

If appropriate ask the participants to form small groups to discuss these issues (some may feel more comfortable about being in a small group for a sensitive discussion).

Make sure that you move around the groups to keep them on track and to ensure that the real issues are being discussed.

Ask what structures exist in the community to build self-esteem for boys and girls.

OR

Activity 4

- ▶ Form the participants into small groups and ask them to think of a role-play where the actors are aggressive, assertive and submissive.
- ▶ Remind the groups that the actor who is being either aggressive, assertive or submissive should remain that way throughout the role-play.
- ▶ Watch the role-plays and discuss which behaviours are effective.
- ▶ Discuss with the large group whether behaviour is dictated by position, status, gender, race, etc., and what impact this has on the way people view others' behaviour.
- ▶ Look again at Appendix 6 and discuss with the group what would have been different if the people in the role-play had all behaved with appropriate assertiveness.
- ▶ Hand out Appendix 6 and ask the groups to fill in the elements of behaviour they saw as aggressive, assertive or submissive, and then to discuss in their groups the possible positive and negative effects of these behaviours.

OR

Activity 5

Instructions

- ▶ Divide the participants into small groups and ask them to think of an imaginary situation (or even one they know of) and project what the actions are likely to be if the people involved are aggressive, submissive or assertive.
- ▶ Hand out the following table [Appendix 7] (or draw it on the board or flip chart) and ask the groups to discuss the elements of behaviour and to write in the possible effects of each of the three behaviours.

Two mothers get involved in an argument that their children are having. One mother screams at the other that her child is a baby bandit and he will never be any good as he is violent and he injured her son. The other mother cries and says that her son is the one injured and she will forbid her son to play with the other one ever again. She takes away her child and goes to the police station to complain.

Constructive (reasonable) behaviour		Destructive behaviour (examples)	
	Assertiveness	Aggression	Submission
Elements of behaviour		abuse anger	crying going to an higher authority
Possible positive effects		vindication (proud that she has won)	justice release of emotions
Possible negative effects		poor role model enmity (made an enemy of the other woman and possibly the family) assumption that aggression is positive	poor role model perceived as weak by community nuisance to the police

Teaching point

Course participants may not have the same categories of assertion, aggression and submission that you do. Do not tell the participants that their categories are wrong; rather, keep questioning why they believe that certain behaviour is accepted or is believed to have a certain effect. Ask if problems arise (or may arise) because of this. Be aware of the cultural differences and, if necessary, point these out to the group.



SESSION 7

Emotional honesty

45 minutes

Discussion

- ▶ Ask the participants what emotional honesty is. [Remind them of the work already done on emotions.]
- ▶ Ask how many of us are truly honest (to ourselves).
- ▶ Explain that emotional honesty does not mean 'losing face' (that only comes when we lose control of our emotions, e.g. losing our temper). Emotional honesty means not letting our pride get in the way of a solution.
- ▶ Emotional honesty is being able to say what is wrong without being emotional and without blaming the other side.
- ▶ Emotional honesty is knowing when the other person is right and having the courage to say so and apologize, without making excuses.

Activity 1

Ask the participants to think of a situation of potential conflict which would have been more simple to resolve if they had not been too hurt or too angry or perhaps too proud to admit that they were wrong.

Form pairs (with people that the participants can feel that they trust) and ask them to tell the situation to the other person (without names or specific details).

The second person should be able to say what actions would have been more emotionally honest.

Get the pairs to swap sides so that the second person tells his/her story as well. Then the first person should identify the behaviours that would be emotionally honest.

In the large group ask the participants why they think people are not emotionally honest.

Keep moving around the pairs – this may be a very sensitive discussion so watch for potential upset.

Allow only 10 minutes as you don't want this to be a long, drawn-out discussion.

Generally people are not emotionally honest because of pride and a wish for revenge. Pride can break up families and send countries to war. While some pride is necessary to develop self-esteem, false pride can be treacherous.

Problem-solving

120 minutes

Discussion

- ▶ Assertiveness is an element in solving 'people problems,' which is linked to emotional honesty.
- ▶ When we are really emotionally honest then the problem is 'depersonalized'. The real underlying problem is the one to be dealt with, the problem, not the people.

Instructions

- ▶ Explain to the group that using assertive language opens the way for good two-way communication and that is a positive step towards solving problems and ultimately conflict resolution.
- ▶ Explain to the group that initially we have to establish exactly what we mean by 'problems'. Often people will say 'there is a problem' and that phrase means a wide variety of things.
- ▶ Essentially there are several types of problems: those with a single solution, those with many solutions and those with no solution.

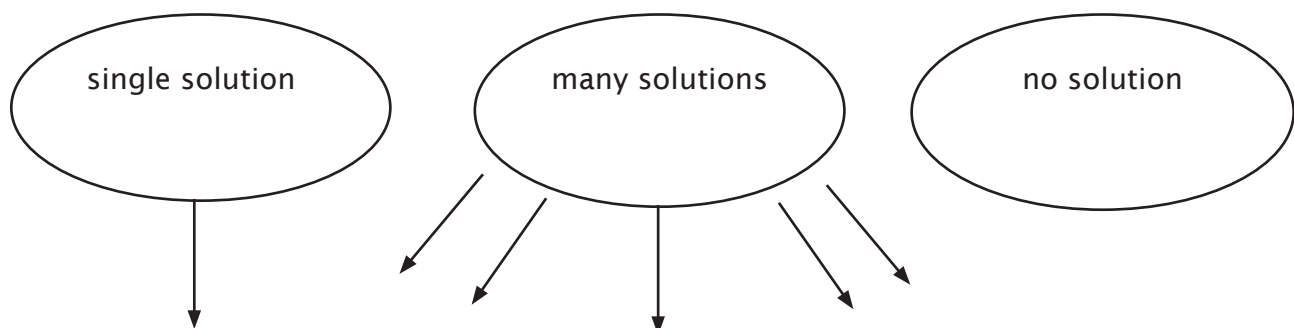

Discussion

- ▶ Often because of our unwillingness to be open-minded, because we are not emotionally honest and because we are used to seeing things in a particular way (because of our background, experiences and culture), we think there is no solution to a problem or only one solution and, if this is not acceptable to the other side then we have a conflict.
- ▶ But problems are different and often there are many solutions but we cannot or do not want to see alternative solutions.
- ▶ Explain to the group that we are going to look at a series of problems.
- ▶ Each of the problems (which are only exercises) demonstrate something about problems and the way we try to solve problems.
- ▶ Each problem teaches us a particular element about problem-solving and it is only when we have done all the exercises that we will have an understanding about the types of problems and the various methods we can use to solve problems.

Make a list on the board or flip chart of the principles of each of the problems as they are done.

Do not write the principles up first; allow the problem to be worked through and then write up the principle.

Ask the participants to form groups of four or five and then ask them to do the following activities.

- ▶ Trial and error is okay, but try not to make the same mistake over and over again.
- ▶ Remember there may be many solutions to a problem just because the method is not the one you would use does not make it wrong.
- ▶ **Never** make assumptions.
- ▶ **Never** give up!
- ▶ Focus on the solution you want rather than going over things that cannot be changed.
- ▶ Remember that your experiences, culture and background will influence (and perhaps limit) the solutions you think of.
- ▶ Be prepared to listen to different points of view; remember there are very few problems in the world with no solution!

Activity 1

Draw this diagram without lifting your pen from the page and without going over the same line twice.

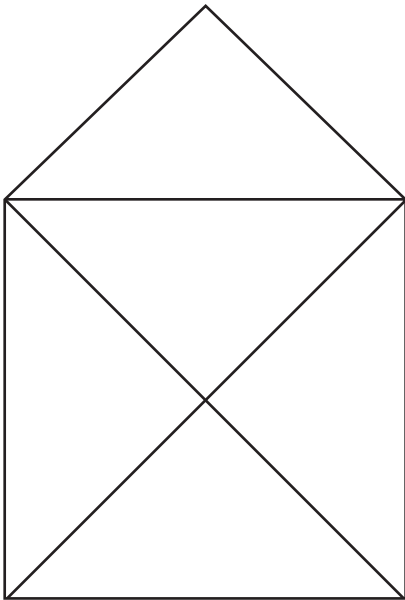

There are three short TV spots in English, French and Spanish which reinforce the message of the Ozzy Ozone. Everyone around the world can make a difference - because when it comes to protecting our planet earth, every action counts. Protect the ozone layer, it protects you!

Give the groups fifteen minutes to complete the exercise and then ask if groups have a solution. (If people have a solution very quickly ask them to do it a different way.)

Move around the groups and check how they are working. *[Remember the problem itself is only an example to demonstrate a point: look do not for the solutions but rather for the way people are working.]*

Look for how many different ways people have found to draw the diagram. Check that people have obeyed the instructions and see whether people have worked alone or in the group. (Generally people use trial and error and people usually work alone.)

Allow people who solved the problem to come to the board to demonstrate how they managed it.

Discuss with the groups how they solved the problem and point out that there is really only one solution. (The diagram must look like the one above, but there are several methods of getting to that solution.)

Discussion

- ▶ Choose one of the papers where the participant has tried over and over making the same 'half-drawing' (i.e. where they have made the same mistake over and over).
- ▶ Ask the group how many people have papers that look something like this.
- ▶ Explain that this is common and that we all make mistakes, and if you don't try you can never get the solution.
- ▶ Ask what the point of this exercise is. [*What lesson have people learned?*]

OR

Activity 2

If the participants are already familiar with the previous problem, try this one. Draw the diagram on the board and explain that the numbers 1, 2, 3, 4, 5, 6, 7 must go in the circles so that the circles that are joined by the lines all add up to 12.

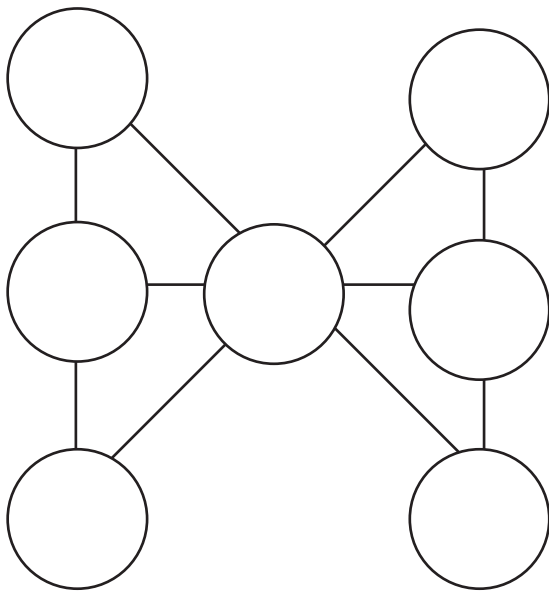

Again give the groups about fifteen minutes to complete the exercise.

Ask if they worked out the principles behind the problem or if they worked 'trial and error' (they just kept putting different numbers in the circles to see if they would work).

Discuss how often we do this in real life ~ try solutions that we already know do not work simply because we do not think of an alternative.

Discuss that sometimes people who are very rigid thinkers want not only the one solution

(i.e. the one they know) but also they want it done the way they do it.

Teaching point

Trial and error is okay to use to solve a problem, but try not to make the same mistake over and over. A method is not a solution; it is a way to a solution. New methods to solve old problems, if they really solve the problem, are just as good as old solutions. Habit is not a solution either!

AND

Activity 3

Instructions

Draw the diagram on the board. Explain the problem to the participants:

Each person (X) lives in the house opposite where he or she is standing (numbered). The snake lives in the house on the other side of the compound. Everyone (and the snake) must go through the compound to get to their houses but none of the paths are allowed to cross. It doesn't matter what time people travel because the paths (the tracks in the sand) cannot cross. You are not allowed to kill the snake and you are not allowed to go around the compound.

Put the participants into small groups for this exercise and watch to see if they work together as a group. [*That is, do they listen to each other and support and build on each other's ideas.*]

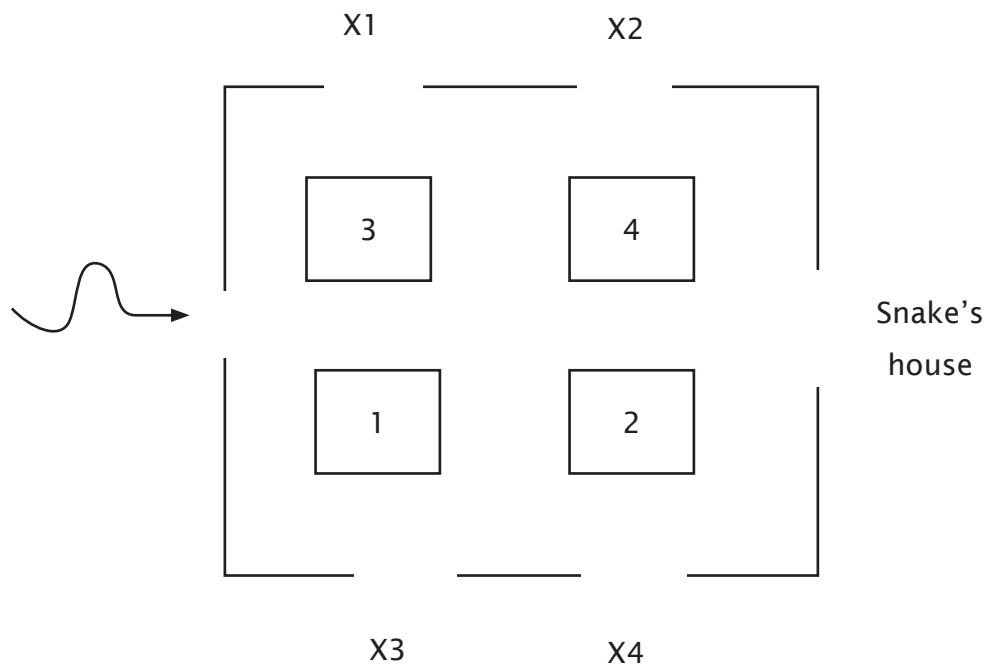

Discussion

- ▶ Discuss with the groups how they solved the problem.
- ▶ Ask what assumption people made that prevented them from solving the problem (that the snake travels in a straight line).
- ▶ Discuss how assumptions prevent us from solving problems in real life because very often we don't realise that we are making an assumption.
- ▶ Ask the group to think of situations where they have made assumptions and so had a difficult time solving the problems they are faced with.
- ▶ Ask about assumptions that are made about certain groups in society; ask if these assumptions are actually bias or even stereotypes. Ask if, as a result of these assumptions, people are discriminated against.

OR

Activity 4

Instructions

- ▶ Be aware that many people are familiar with this problem but cannot quite remember how it is done.
- ▶ Explain to the groups that you want them to try another problem.
- ▶ Draw the nine stars on the board in the shape of a square and tell the participants that all the dots must have a line passing through them but that only four straight lines may be used. They cannot go over the same line twice. They must not lift their pens from the paper.

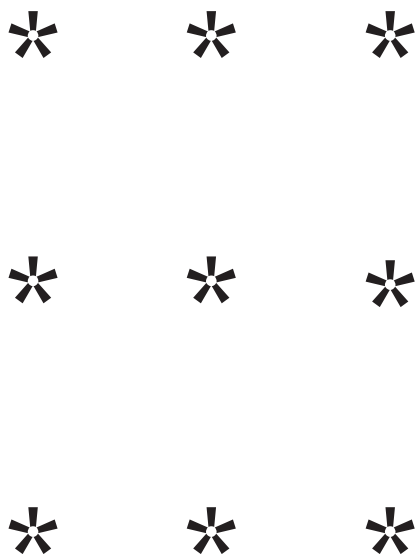

Allow the groups ten minutes to try for a solution. If, at the end of ten minutes nobody has a solution, ask the group why the problem is so difficult (usually the responses are that it is not possible, that they need five lines or alternatively only eight stars). Remind the groups of the limitations – nine stars and four straight lines – and reassure them that it is possible but that they must ‘think big’.

Allow another five minutes.

If participants feel that they have the solution allow them to demonstrate on the board.

Ask why people feel that this solution is not appropriate (if they have made comments which suggest this).

Ask if they made an assumption that the lines must stay within the boundaries of the stars (inside the square).

Discussion

- ▶ Discuss the fact that often we make assumptions and that these assumptions themselves may cause problems.
- ▶ If we make assumptions when we try to solve problems, these assumptions limit our solutions.
- ▶ Discuss that assumptions are based on our background, culture, experiences and (sometimes) exposure to other ways of thinking. It is an extension of empathy to try to control our assumptions and really try to see why others may think in another way to ourselves, and to accept that they may be right.

AND

Activity 5

Instructions

This is another problem about assumptions. Use it if most participants do not understand the point about assumptions causing a problem and limiting a solution.

Tell this story:

There is a senior professor at the university. The professor is charming, distinguished and dresses well. The students like and admire the professor, and the lectures are always interesting. Every Wednesday the professor goes with the other professors to drink tea and discuss the state of the world. One Wednesday the professor misses the afternoon of tea and discussion.

Why?

Because her child is sick.

Discussion

- ▶ Ask participants which sex they thought the professor was while you were telling the story.
- ▶ If participants say that this could not happen, ask others if they agree.
- ▶ Explain that there are many female professors in the world and that if they automatically assumed that 'professor' equals 'man' then they have made assumptions based on culture or experiences, but that does not make them the truth.

Teaching point

If we are going to resolve problems, it is vital to **never** make assumptions

OR

Activity 6

Ask if the participants can solve this problem:

There are 100, 000 refugees in a camp of a certain country in the desert. Underneath the ground of where they are settled there is water and bore-holes are drilled to pump the water to the surface for the refugees. When the refugees first arrived, there was a water table (the water underneath the ground) of an estimated 1,000 million litres.

The refugees get 10 litres of water per person per day. So in one year,

- ▶ How many years will the water last?
- ▶ What are the assumptions that the refugees make about the water?

Discussion

If the participants do not offer these suggestions ask them what they think about them:

- ▶ There is always water.
- ▶ The refugees should have their water restricted.
- ▶ It is not the problem of the refugees; it is a problem for UNHCR.
- ▶ God will provide.
- ▶ By the time the water runs out, the refugees will be gone.

Teaching point

The idea of assumptions limiting our problem-solving ability needs to be reinforced. Allow as much discussion as necessary to help participants see what kind of 'boxes' they are in as a result of assumptions that they make. Give examples from your own experience where you have made assumptions, which limited the solutions, you could think of.

The assumptions that are made about situations often mean that people do not see a problem coming and, when it does, there is a tendency to blame somebody else for the problem.

AND

Activity 7

Make sure that people work in small groups to solve this problem. This problem is one most people know but it is worth doing as it offers positive reinforcement to the participants and allows them to look more closely at the methods they use as a group to solve problems. It is a problem of logic, and problems of logic must be worked through.

Tell this story:

A man was coming home from the market with a goat that he had bought and a fine green cabbage. He captured a wolf and decided to take it home as well. He came to a river, which he had to cross in order to get home, but the boat was very small. It would take the man and only one of the other items. If he left the goat and the wolf, the wolf would eat the goat; if he left the goat and the cabbage, the goat would eat the cabbage. How does he get all three across the river?

Discussion

- ▶ Ask several of the groups to demonstrate how the problem is solved.
- ▶ Ask how groups solved the problem.
- ▶ Did anybody give up because they could not 'work through' the problem?
- ▶ Who knew the problem already?
- ▶ Did anybody build on somebody else's ideas?
- ▶ Discuss with the groups whether they felt they worked as a group.
- ▶ Ask what it means to work together as a group. (Does it mean that one person told and the others just listened?)
- ▶ Ask why it was easier to work together as a group for this problem than for the previous problems.

If people do not know the problem, this is the time when the groups actually work together, designing solutions, discussing and offering alternatives.

Move around the groups to find examples of this where possible. Even where the participants do know the answer, usually they cannot quite remember how the solution works and the same process takes place (but not so obviously).

If people do know then usually the one who knows explains it to the rest of the group and the 'drawing' of the solution takes place as part of the explanation.

Teaching point

This problem has at least two methods of solution. The teaching point here is to positively reinforce the participants, especially if they have not been particularly successful with the previous problems. This is usually the first problem where the group works together. Analyse how this 'working together' was undertaken.

AND

Activity 8

- ▶ Tell this story and ask the participants to work in small groups to try to solve the problem.

Two men are carrying a pot with 8 litres of oil in it. As well they have an empty 5-litre container and an empty 3-litre container. There are no markings on the containers. At the end of their journey they must divide the oil equally so that they have four litres each. How do they do it?

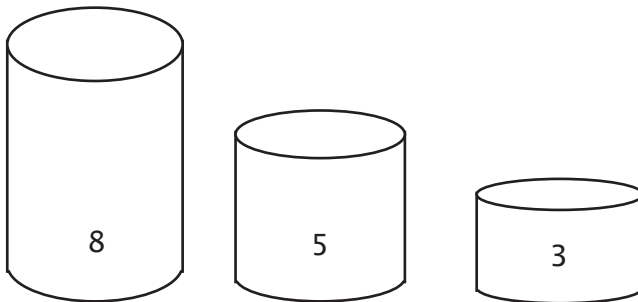

See appendix 8 for possible solution

Discussion

- ▶ Why was this problem difficult to solve?
- ▶ Did the groups work together as groups? *[People do not generally listen to each other in this problem and so cannot solve it.]*
- ▶ Discuss how in attempting to 'solve' the problem, people actually create new problems by not bothering to work through the problem, but by looking for 'short-cuts'.
- ▶ Ask about real life problems that have no short cuts; they must simply be worked through. Generally these are the problems that remain unsolved. Ask for examples.

Keep in mind that people get 'stuck' because they do not think about the space left in the containers.

Remind people to work through the problem and not to give up.

Alternative solutions such as taking a container instead of the oil, selling the extra litres (that they cannot divide) or 'measuring' using a stick or rope are not real solutions (what if the containers are odd shapes?)

These create more problems that then in turn have to be solved.

Teaching point

Both this problem and the previous one are problems of deductive reasoning. The only way to solve the problem is to keep working through it logically. Anger, frustration and giving up do not solve the problem. Many real-life problems are like this: people get angry and argue about other issues, e.g. how long each man carried the oil; how many people each one has to feed; how important one man is in comparison to the other, etc. None of these is the real problem and none actually solves the problem.

AND

Activity 9

Explain to the groups that they have to organize a knockout chess or football competition. (A knockout competition is where the players/teams play only as long as they are winning. As soon as players/teams lose a game, they are out of the competition.)

There are sixteen players/teams in the competition. How many games need to be played to find the champion team?

Write up all the number of games suggested. Allow as much discussion as is needed. Then ask how many winners are needed at the end. Allow the group to respond. Groups will generally answer 'one'.

Ask then how many losers there are if there is one winner. [15]

This problem demonstrates that to focus on the solution that you want can solve the problem more quickly than trying to work through the problem.

Note: Walk around the room to see if participants draw a diagram something like the one below. Sometimes they will simply write 8, 4, 2, 1. This is still working through the problem.

It is not necessary to draw the diagram yourself as it reinforces 'working through' rather than going directly to the desired solution. It may be drawn if you have seen it in the groups working out.

Emphasize (if necessary) at the end of the competition.

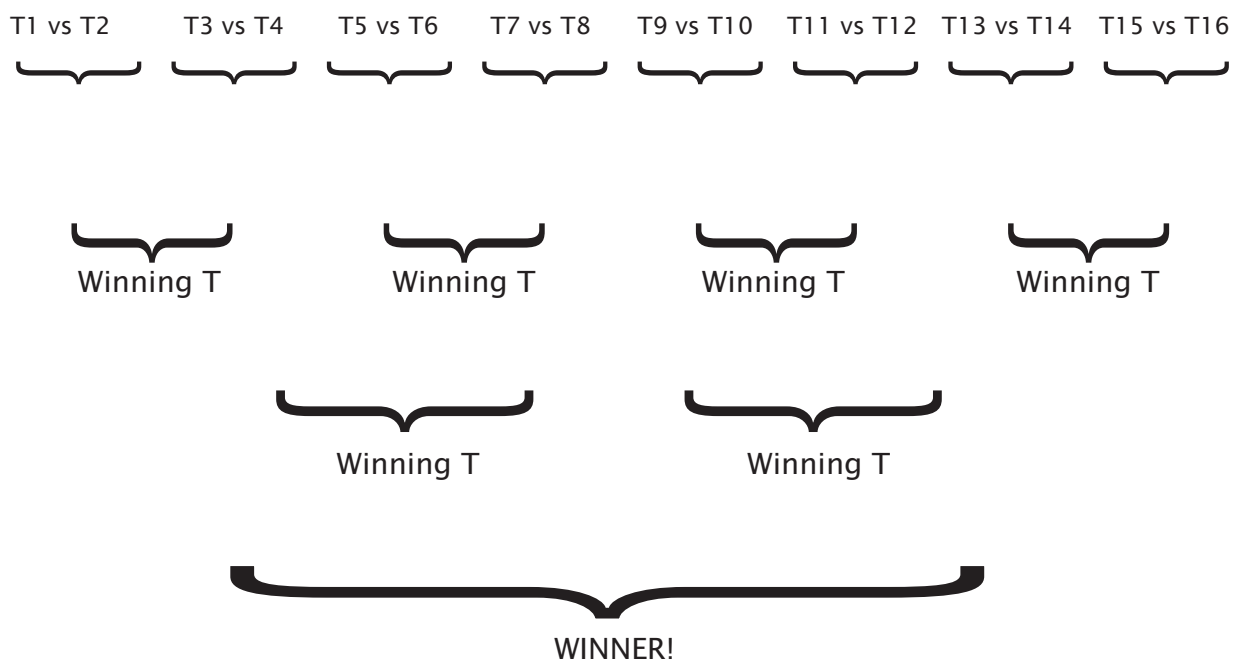

Discussion

- ▶ Point out to the participants that many problems are like this.
- ▶ Sometimes it is better to concentrate on the solution rather than trying to work out the problem.
- ▶ This does not mean that the past should be ignored but it does mean that more effort should be spent on the future than on the past.
- ▶ If we try to work through the problems in a chronological manner, there may be other problems that come from trying to solve it this way.
- ▶ Usually there is a lot of blame, bitterness and a desire for revenge attached to things that people have done and said during the time of the problem.
- ▶ In conflict situations, after hearing people's views about the past, it is necessary to turn away from the past and look to the future, to the needs people have for the future, and concentrate on them.
- ▶ Ask the participants to remember this when we come to the unit on negotiation and mediation.

This problem emphasizes 'seeking the solution' as opposed to 'working through' the problem.

Do not concentrate on how people worked through their answers.

Allow enough time for people to see that it is a lengthy process and then cut through to 'seeking the solution'.

Point out that many problems have so many layers of problem with wrongs on both sides and time for resentment to take hold.

A 'seeking-the-solution' approach concentrates on what both sides what now and can agree on.

It does not concentrate on trying to right past wrongs.

AND

Activity 10

Instructions

Tell the participants the story (in the box):

Form the participants into groups and allow them ten minutes to discuss as many solutions as they can find.

Ask them for solutions. How can this problem be solved?

A beautiful young girl had a father who was a gambler and who had got himself heavily into debt. The moneylender wanted to throw him into prison (where he would surely die) but then he saw the beautiful girl walking past in the garden. When he saw the beautiful daughter he said that he would let the father go free if the daughter agreed to marry him.

The father went to explain to his daughter that the moneylender wanted to marry her but the girl was horrified. The moneylender was old and ugly and horrible. The girl refused but the father begged, saying that if she did not marry the old man he would have to go to prison where he would surely die. The girl wept and pleaded but she loved her father and she was a good and dutiful daughter, and she wanted to save her father but the moneylender was truly horrible and she could never marry him; so she was trapped.

The moneylender could see that there was a problem and so he asked if he could talk to the girl alone. They walked a small way down a path through the garden. The path was a gravel path made of black and white stones. The moneylender said, 'Look, I have an idea. I will put a black stone and a white stone into this bag. You pull out one stone - if it is the white stone your father will go free and you will not have to marry me - if it is the black stone your father will go free but in return you must marry me.' The girl had no choice and she felt that this way at least she might have some chance to go free.

As the moneylender bent to pick up the two stones from the path the beautiful girl saw that he picked up two black stones and put them into the small bag. She cannot accuse him of cheating because her father's life is in his hands.

What does she do?

Generally the solutions will fall into several categories:

- ▶ those that say that either the girl (by marrying) or the father (by going to prison) has to live with the consequences of their actions or decisions: - those are legalistic solutions;
- ▶ those that say that the girl should marry and then divorce, or marry and run away because the money lender is not an honourable man, or that the man is a cheat and therefore she should not have to marry him: - those are moral decisions made by the problem solver but they do not solve the problem;
- ▶ those that ask for witnesses, or suggest some form of stone swapping: - those are intellectual solutions (or 'intellectual' solutions).

Allow each group to explain its solution.

It is not necessary to categorize the solutions unless the group is having difficulty accepting alternative solutions.

Discussion

Point out the shortcomings of each of the solutions offered: an unhappy wife can make the whole household miserable, and does this solve the problem? The moral judgements do not actually solve the problem. Adding to the story may give leeway to a solution, but there are no witnesses (they are alone in the garden).

Point out that when problems involve human emotions, they become more complex and issues such as the morality and legal aspects all play a part.

Each of us makes judgements based on our experiences and values (remember perceptions), but if we are to try to solve or resolve problems and conflicts, then we need to look for solutions that do not hurt people or cause them to 'lose face'.

We need solutions where everybody can feel that they have won or kept something, that is to say, they have not lost. Often our desire for revenge makes us want to hurt people or humiliate them.

Teaching point

Never 'give' an answer yourself. If the group is particularly passive the participants will simply accept your solution as the 'correct' one and not attempt to draw a principle from the problem-solving.

This problem should lead naturally into the idea of 'win/win' solutions. The point is not to find a particular answer but to point out another aspect of problem-solving.

At this point the participants should be aware that:

- ▶ problems may be done alone or with a group;
- ▶ some problems have multiple solutions or multiple methods;
- ▶ complex problems may lead to more complications or a 'no solution' if they are 'worked through' and that there may be creative (or lateral thinking ways) of getting to a desired solution; and problems involving human beings and their emotions are open to bias, and perceptions and assumptions dictated by our bias.



Different types of problems require different 'keys' to find solutions.

SESSION 8

Problem-solving continued (six steps)

Activity 11

90 minutes

Instructions

Put the participants into small groups and ask them to develop a drama from the cards you hand out. The cards should have one topic each as follows: a mother accompanying her daughter to school but not trusting the teachers; an unwanted pregnancy in a school girl; a misunderstanding through lack of trust between a husband and wife; a girl not allowed to continue at school; a boy/man discovering that he has a sexually transmitted disease (STD).

Ask two or three groups to present their dramas.

Put up the chart **'Six steps to problem-solving'** [Appendix 9]. Go through the dramas that you have seen, asking the questions on the left hand side of the chart to each group.

Remind the participants that they must answer in their roles as honestly as they can (i.e. they must imagine what their character would say)

Six steps to problem-solving

What do you want?	Each side should say what they want but without blame or accusation	This often reflects the emotions involved, not the actual problem. Point out that mostly what people want is revenge or 'payback'. Even when this is part of the culture, it rarely solves the problem.
What is the problem?	Both sides must agree on the problem (i.e. identify the same problem)	This forces people to concentrate on the real problem, not their emotions (although it takes a lot of emotional honesty sometimes to actually agree on what the problem is).
How many solutions can we find?	Both sides need to propose as many alternative solutions as possible so that there is a choice and the best possible solution is found	This takes intellectual effort. Often we are lazy and assume that there is no solution, or that the other person is the problem. For good problem-solving there should be several solutions (even if neither side actually wants a particular solution; if it is a solution, then it should be proposed as a solution).

Would you be happy with this solution?	Both sides need to look at the possible solutions and disregard those that are totally unacceptable.	Both sides should have a choice to find the most suitable solution, but the solution must be genuine and fair, not a solution that favours one side or the other.
What is the best solution?	Both sides should agree on the best solution for everybody.	Both sides must agree (in their hearts) on the solution that is best for everyone. There should never be a solution that people agree to 'just to keep the peace' (this will create the potential for another problem later).
Is the problem solved?	After some time, we made need to check that the solution is really working.	All solutions should be checked to ensure that they are real solutions and that there is no resentment.

Adapted from UNICEF, *Education for Conflict Resolution. A Training Manual*, New York, UNICEF, 1997.

Discussion

- ▶ Discuss the aspects of the chart (listed in the grey boxes)
- ▶ Ask the participants to look at where the steps are introduced into the drama situation and how using the steps would change what had happened.
- ▶ Explain to the group that some of these elements will be dealt with again in the unit on 'Negotiation'.

Teaching point

Problem-solving is only really successful when all the elements so far covered in the course are put together with the skills of logic and problem-solving. The essential point of 'depersonalizing the problem' is vital.

AND

Activity 12

Instructions

Explain to the participants that problem-solving usually falls into one of three categories:
win/lose; lose/lose; win/win.

Ask for some examples of each of these.
Draw the chart below on the board or flipchart.

- ▶ Ask participants to describe some problems that have been solved (in the community) and how they were solved.
- ▶ Ask the group which column they think the problem and its solution should go in.

War is often considered win/lose, but a better example would be the law courts where one person is found guilty and the other innocent.

Lose/lose is often actually war as both sides lose lives and property and suffer destruction.

Win/win is any successful negotiation (such as bargaining in the market) where both sides are satisfied with the outcome.

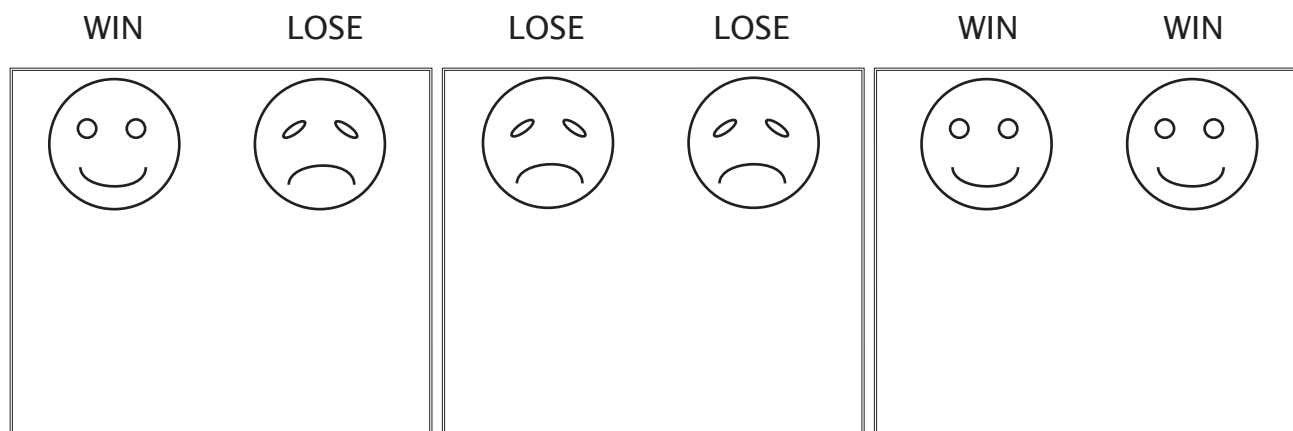

AND

Activity 13

Instructions

- ▶ Group participants into small groups and ask them to think of a conflict situation, which they will role-play.
- ▶ The role-play should show all of the skills discussed so far in the course and the role-play must try for a win/win solution.
- ▶ After the role-plays have been shown, ask those involved why they think it was a win/win solution. Ask the audience if they agree.

- ▶ Write the problems into the columns the participants think they belong to and discuss why they are in that particular column.
- ▶ Discuss with the participants that a solution that is acceptable culturally is not necessarily win/win. It is win/win when both parties feel happy with the solution and that solution is 'real'.
- ▶ Explain that as far as possible all problem-solving should result in a win/win solution.
- ▶ When a problem does not end in a win/win solution, then there is no durable solution as there is often resentment, a desire for revenge and a hatred for the person who 'won' if you 'lost'.

Be aware of your own cultural bias.

Very often people will assume that a problem is solved because somebody in authority says it is solved. This does not change what is in people's hearts and often there is a need for revenge (especially if one person has 'lost face').

Question deeply, and ask, 'what happens next?' both to the participants and inside your head.

Win/win solutions require the person trying to solve the problem to empathize with the other person and understand what his/her needs are and to match those with what his/her own needs. This requires emotional energy and a real will to solve the problem rather than just stop it.

- | | |
|----------------------|--|
| R Realistic: | applicable not only in theory but also in practice |
| E Effective: | the solution is an answer to the problem |
| A Acceptable: | the solution is accepted by all those involved |
| L Logical: | the solution is not based on emotion but is fair |



Negotiation

90 minutes



Instructions

Outline the process of negotiation drawing on examples from the workshop and/or from the participants' conversations.

The process of negotiation

- ▶ Negotiation is the ability to 'give and take' in a dispute so that a conclusion is reached that is acceptable to all parties.
- ▶ It is undertaken by the two people (or groups) involved in the conflict, without any outside intervention.
- ▶ It requires both people to concentrate on the problem and not on each other (and the perceived faults of each other).
- ▶ The art of negotiation is to find (initially) one thing where both parties agree.
- ▶ Even an initial agreement helps to dissolve some of the anger and mistrust both sides feel. (This is why mediations are often successful, because the mediator can agree with the emotions of both sides.)
- ▶ Once there is an initial agreement (and it should first be about exactly what the problem is), then you can begin to define what the needs are of each person.
- ▶ To deny that there is wrong on both sides can never lead to a resolution, so initially one person has to say that they were wrong (this is usually difficult and the admission is generally about something small).
- ▶ Both people need to understand and empathize with the emotions of the other. They do not have to agree but they need to try to understand why the other person feels as they do.
- ▶ When one side can acknowledge that the other has reason for feeling as he/she does, and acted out of that feeling (not just to be malicious), then the problem can be addressed.

Discussion

- ▶ Allow the participants to discuss if they feel negotiation is possible.
- ▶ Discuss the fact that, even if traditionally a third person is brought in, nevertheless people still have to negotiate (but the negotiation is with the mediator and between the mediator and each of the people or groups concerned).

Activity 1

- ▶ Group the participants into pairs.
- ▶ Ask them to think of a problem (either real or imaginary) which they should try to solve through negotiation.
- ▶ Remind the groups of the work already done on problem-solving.
- ▶ Allow the pairs about ten minutes to work through their problem and then ask who feels they have arrived at a win/win solution just through the two people concerned.
- ▶ Ask the rest of the participants if they feel it is really a win/win.
- ▶ Allow the other groups to discuss why theirs was not a win/win and why this happened.
- ▶ Allow discussion of the solutions and listen for the compromises made by each side.
- ▶ Discuss if the negotiators dealt with the person or the problem, and which method they used . (Refer back to the section on problem-solving; did they work through the problem or try just to define a solution?)
- ▶ Give the participants the handout with the negotiation questions [*Appendix 10*] and go through the list using one or two of the examples that are particularly notable discussing each of the questions.

Negotiation questions

(To be asked by each person of themselves; **not** the other person)

What feelings or emotions do you have about this problem?

What do you really need? Is this different to what you want?

If you concentrate on what you really need, is it possible to compromise?

What behaviours do you show that may stop the other person from getting their needs met?

Does the problem change in the course of the conflict?

How is the problem resolved?

Activity 2

- ▶ Explain to the participants that because of emotions, bias and assumptions, people often have a conflict, not necessarily because of their needs but because of their positions.
- ▶ Refer back to the problem of the nine stars and remind the participants that when we are bound by our assumptions we often cannot find a solution.
- ▶ Discuss how needs and positions are usually very different although the people involved may not be able to see the difference.
- ▶ Hand out Appendix 11 and discuss whether in any of the problems previously discussed people tried to resolve their positions rather than their needs.
- ▶ If necessary use the following story as an example.

There is an argument between two men over money borrowed and not repaid. The first person (who borrowed the money) claims that he has repaid the money by helping the first person to get what he needs from an agency. He speaks badly of the second person around the community claiming that he is a liar and a cheat. The second person hears of the gossip and is angry and humiliated. He, in turn, claims that the first person is a cheat and a thief as the money has not been returned and that he needed no help in dealing with the agency. The two feel very bitter towards each other and there is tension in the community as people start to take sides. They decide to try and negotiate an agreement and so they meet in a coffee shop to discuss the problem.

The position of person 1 is indignation as he feels he paid the money in kind by doing the favour.

The position of person 2 is anger and frustration as he has not received his money and now he is publicly humiliated. He wants revenge, his money and an apology.

The needs of person 1 are to be understood and to have his good name restored.

The needs of person 2 are to have his money returned and to have a public apology.

Both people are limiting the resolution because both want an apology but neither is willing to sacrifice his pride.

The problem has changed in the course of the conflict by the fact that both people talked to others and so added humiliation to the problem.

Person 2 explains that he feels bad because his name and reputation have been damaged. Person 1 insists that because he helped with the agency problem, he returned the money 'in kind', and his reputation and good name have also been damaged. The second person insists that he did not need help with the agency as he has contacts there. He asks the first person what exactly he did to help. After the first person cannot tell him, they agree that at least the money should be repaid. They agree that the money should be repaid in instalments, which will be monitored by an elder. They are still too angry about the insults to apologize to each other.

Thus the initial problem is solved but this is not a durable solution.

Discussion

Draw from the discussion (where possible) to list the Rules for Negotiation

[Appendix 11]

RULES FOR NEGOTIATION

Keep the problem and the people separate.

Look at the problem objectively, without concentrating on the personalities involved

Concentrate on responding to needs (of those involved) not positions (i.e. not their perceived status, or emotional state).

Find as many options as possible to answer the other person's needs.

Be as objective as possible.

Seek a win/win solution.

- ▶ List these rules on the board or flipchart and then give the handout to the participants.
- ▶ Remind participants that most problems in fact have many solutions but this needs a lot of work (and analytical thinking).
- ▶ They need to continually try for different solutions in order to get a win/win solution.

SESSION 9

Mediation

60 minutes

Discussion

Traditional mediation is often undertaken by people who have status in their society. Unlike 'textbook' mediators, traditional mediation involves giving advice, conciliation by proxy and passing judgement with the communities involved to help recompense the victim. While this is usually accepted by those involved, it does not always involve durable resolution and reconciliation.

Instructions

- ▶ Ask participants why this may be so. *[Those involved do not have to accept responsibility as the responsibility belongs to the mediator and the two sides do not have ownership of the solution.]*
- ▶ Discuss with participants what elements of traditional mediation work in their current situation and which do not. *[There may be a breakdown of social pressure; which is what makes people conform to the mediator's advice, or the mediation may come from people outside their cultural or social group.]*
- ▶ Even where traditional mediation is undertaken and is successful, all the skills so far introduced and practised need to be taken into account by both the mediators and the people involved.
- ▶ If the two parties involved are not willing to listen or trust the mediator then the mediator cannot be successful.
- ▶ If the mediator is biased or uses force to impose a solution, then the solution will only cause more problems later.
- ▶ A good mediator will ask the two parties to communicate with each other (not immediately, when there is anger, but at some point in the mediation).
- ▶ A good mediator takes into account the emotional needs of the people concerned, acknowledges these and then moves on to solve the problem.

Activity 1

- ▶ Form groups of four participants. Two protagonists, one mediator and one observer.
- ▶ Give the groups five minutes to set up a problem situation and then ask the mediator to mediate.
- ▶ The observer should note all negative and positive actions of both the protagonists and the mediator.
- ▶ After five minutes, ask the groups to discuss the issues raised by the observer and then get people to change roles.
- ▶ Each participant should have an opportunity to be an observer and a mediator.
- ▶ At the end of the exercise, ask people to describe what their group said and did that showed (or did not show) skills of mediation.
- ▶ Hand out the checklist to help focus discussion of people's behaviour. *[Appendix 12]* and analyse at least one of the scenarios using the checklist.

Mediation checklist

Do you actively listen to each protagonist?

Have you checked yourself for any bias or discrimination?

Do the protagonists actively listen to each other?

Do the protagonists actively listen to you?

Are the protagonists communicating clearly?

Are they emotional?

Are they honest?

Are you honest?

Do you feel that the protagonists trust you?

Have you looked for areas where the protagonists are willing to compromise?

How many alternative solutions can the group come up with?

Can you find a solution that is acceptable to both sides?

Do the protagonists feel that they can forgive each other?

Is there a reconciliation?

Reconciliation

120 minutes

Reconciliation is when the two parties in a conflict come to a solution that is durable (long lasting). This is when we have true peace. It means that there is no resentment and that there is a strong win/win solution so that both parties feel happy with the outcome and feel positive about each other.

Activity 1

- ▶ Form groups of five to eight participants.
- ▶ Give each group flip chart paper and a marker pen.
- ▶ Ask the groups to list all the elements needed in a conflict situation so that there can be a true resolution and a reconciliation.
- ▶ Put the sheets up around the room.
- ▶ Discuss with the groups the elements that are needed for reconciliation. Point out that win/win solutions can only occur if both parties are willing to work towards this. It is not necessary for both sides to be 'peacemakers' but the side that is the peacemaker will be aware of the emotions of themselves and the other side and how these emotions affect our behaviour.
- ▶ Distribute the handout [Appendix 13] and discuss it with the participants.

Discussion points	
Denial If we think of situations where somebody has wronged us (whether it is an individual or something like war), very often our immediate response is 'This cannot be happening'. This is sometimes very quick and we move almost immediately to the stage of hurt.	Denial If we have wronged others, we tend to be defensive and deny that we did anything wrong. Then we try to justify why we did (because we cannot blame ourselves).
Hurt All we can feel is the emotional pain of being betrayed or wronged by somebody. We are not yet angry with the other person, because we are in too much pain. Sometimes this stage is also quick but if it is somebody we trusted or somebody very close to us this stage may take a long time before we move to the next stage.	Anger When we are confronted with the hurt of the other person, we generally have to admit that we did something wrong (but we don't admit that). Then we become angry and we project that anger onto others (to try to put them 'in the wrong').

<p>Anger</p> <p>As the hurt fades, people become angry. This is often the stage when people start to think of revenge.</p>	<p>Remorse</p> <p>This is not to be confused with truly being sorry. This is when people are sorry that they were caught, not sorry for what they have done. People often apologize at this stage to stop the other person's anger and to relieve their own guilt (at this stage people understand that they have done wrong but they cannot yet admit it).</p>
<p>Empathy</p> <p>This is an effort of will, where the person attempts to understand why the other person may have acted as he/she did. This requires the person to put aside emotional reaction and to analyse both his/her own behaviour and that of the other person as well as the situation. Once the individual can see why the other person acted as he/she did, it is possible to relate to that and so become empathetic</p>	<p>Empathy</p> <p>Once the person has admitted to himself/herself that they have done wrong it becomes easier to understand why the other person reacted as he/she did. When there is this understanding, empathy can follow.</p> <p>This is the stage that decides whether the problem can be resolved and whether there can be a reconciliation or whether the cycle of conflict will simply continue.</p>
<p>Resolution</p> <p>Because the emotional aspects can be put aside, it is possible to concentrate on the problem. Through the level of empathy, there is an understanding of the other person's point of view so that it is possible to promote solutions that will be acceptable to both sides.</p>	<p>Resolution</p> <p>Once there is empathy with the other person and it is possible to see the situation from the other's point of view and the emotions have been acknowledged, then it is possible to work through the problem and propose solutions. This stage is just the problem-solving, not the healing stage.</p>
<p>Forgiveness</p> <p>When the other person asks for forgiveness, this is the start of the healing process. If this is rejected, the process goes back to the hurt and anger stages. True forgiveness is when there is no 'holding' of the hurt and no attempt at revenge. Forgiveness is not just healing for the situation and the relationship, but also for the person who has been most hurt.</p>	<p>Asking forgiveness</p> <p>In order for the healing to start the person must be willing to admit his/her mistake and be genuinely sorry; sorry for the hurt caused and sorry for the action (this is different to being sorry for being found out). At this stage, it is possible to ask for forgiveness, but it takes an effort to overcome the pride.</p>
<p>Reconciliation</p> <p>Once the problem is resolved, and the emotional hurt has been acknowledged and apologies have been accepted, the situation has now been resolved, and this allows the two people to be reconciled; to start the relationship again in a positive and constructive way.</p>	

Handout (Appendix 13)

		First person (person who has been most wronged)	Second person (person who has most offended)
	Problem or conflict situation	—————→	
Time	Reactions	Denial Why has this happened to me? Why did he/she do this? It must be my fault! (submissive behaviour)	Denial I didn't do it! You forced me to behave that way (aggressive behaviour)
		Hurt There is a focus on the emotional pain caused (submissive behaviour)	Anger Where the person becomes angry and resentful at being put in the 'wrong' (aggressive behaviour)
		Anger There is a focus on blaming the other person (aggressive behaviour)	Remorse Where the person wants to relieve conscience and guilt
Time		Empathy Where there is understanding of the other's emotions and an attempt to understand the motives behind the wrongdoing	Empathy Where there is understanding of the other's emotions and an attempt to understand the hurt and anger
		Resolution Where the problem is 'depersonalized' and solutions are sought and agreed to	Resolution Where the problem is 'depersonalized' and solutions are sought and agreed to
		Forgiveness Internal peace and 'letting go' of the pain.	Asking forgiveness If genuine, then an internal peace and 'letting go' of the anger and the aggression
		Reconciliation	Reconciliation

Discussion

- ▶ Ask if participants can see these steps in a situation that they know of where there has been a genuine reconciliation.
- ▶ If there has been no reconciliation, which step do they feel is left out, or what other things happen to prevent a reconciliation? *[e.g. often when person 1 reaches the point of anger, he/she responds with aggressive behaviour, harsh words or actions to the other person which add another layer to the 'conflict cycle'. If there is no empathy on either side, then there will not be a reconciliation although the conflict may be managed or apparently resolved. If either side 'hangs on' to the hurt or anger, through habit or pride, status or 'culture', then there can be no reconciliation.]*
- ▶ Reconciliation may take a long time to occur. Trust must be rebuilt, there must be open and honest communication, and both people or parties must feel ready for reconciliation. They must both work through all the stages in the handout. *[Appendix 13]*



SESSION 10

Human rights

160 minutes

Activity 1

- ▶ Brainstorm with the participants about human needs.
- ▶ Put all the needs that are suggested up on the board or flipchart.
- ▶ Categorize the needs into **physical needs** (life, food, water, shelter, health), **mental and emotional needs** (education, belonging to a country and a society, being loved) and **spiritual needs** (right to worship the way it is appropriate for you).

Discussion

- ▶ Discuss with participants, which of these are inherent rights, which are rights within the resources of the state and which are visionary for the future?
- ▶ Ask participants the difference between wants and needs.
- ▶ Ask if the Universal Declaration of Human Rights is a response to needs or wants.
- ▶ Allow discussion on where human rights are not being observed and why. Is it power? culture? tradition? religion? Before the fighting that made people flee, were human rights observed in that country?
- ▶ Discuss the fact that human rights are not given from above but each one of us has to allow them to another. The state (the country) does take responsibility for some rights that properly belong to the community, but the spirit of human rights is that we as individuals grant them to each other.

OR

Activity 2

- ▶ Brainstorm all the human rights the group can think of and put them down one side of the board.
- ▶ Ask the group now for the corresponding obligation we have as human beings to ensure that the right is available to all.

Discussion

- ▶ Ask the participants if they have ever stopped anybody from exercising their rights.
- ▶ What about their daughters, their wives and the peasants in rural areas? What about child soldiers, torture and not employing people from another tribe or clan?
- ▶ Ask how they can justify these human rights abuses when they are asking for human rights to be granted to them.

OR

Activity 3

Instructions

Divide the participants into small groups of four or five.

- ▶ Ask them to discuss the list of the inherent human rights that they drew up earlier and how in this community we can now work towards protecting these rights.
- ▶ Each group should bring back their ideas to the plenary group for general discussion.

Discussion

- ▶ Ask groups to highlight or asterisk (*) any 'rights' they have asked somebody outside their community to 'give' them.
- ▶ Ask why this is so.
- ▶ Ask what abuses of human rights exist in their community and how these can be overcome.

AND

Activity 4

Instructions

- ▶ Draw a line down the centre of the board; one side is for the work that women do, the other side is for the work that men do.
- ▶ Ask the participants to list the things that each sex does and encourage the discussion that arises.

Discussion

- ▶ Among the 'visionary' rights are the rights of women.
- ▶ The reason for these rights being introduced is that women across the world do approximately 80 per cent of the work but own less than 2 per cent of the world's wealth.
- ▶ Women in most countries are not recognized as equal although everybody agrees that equality is a fundamental right.
- ▶ Remind the group that 'culture', 'religion' and 'tradition' are often excuses rather than reasons.
- ▶ All cultures change; ask in what ways the cultures represented have changed in the past fifty years.
- ▶ Point out to the participants that no group that has power will readily relinquish it. This is not about men and women; it is about those who have power and those who have very little, whether they are male and female, black or white, rich or poor, or different religions.
- ▶ If we are serious about the equality inherent in human rights, then we need to look, not just at how we are constrained, but at how we constrain others. When we all work together for the good of all, then we will have human rights.
- ▶ Some rights have been forfeited when people become refugees. Although Convention refugees have the same rights as a citizen of a country (except the right to vote), mandate refugees have legal rights under the laws of the country of asylum, the international rights of those documents signed by the country of asylum and the right not to be forcibly repatriated.
- ▶ Allow the discussion to flow naturally. It is important that the participants feel that they are able to talk about this area freely.

OR

Activity 5

- ▶ Put the participants into small groups and ask them to list the rights that women have in their own culture.
- ▶ After the groups give their feedback, ask how these equate to the human rights they listed in a previous exercise.
- ▶ Discuss why these lists may not be the same and what causes this to be so.
- ▶ Ask how they (as individuals) will ensure that women will have equal rights, without detracting from the rights of others.

AND

Activity 6

- ▶ Ask participants to list what they think are the rights of the child.
- ▶ Form groups of three and ask people to compare their lists.
- ▶ Ask two groups to get together (so that there are six people to a group) and ask them to list the ways their communities protect the rights of the child and the abuses of children that happen and that contravene the rights of the child. [*Rights: family love, education, religion, care, no torture, no work too heavy for the child, etc. Abuses: child soldiers, child marriages, forced marriages, no education, etc.*]
- ▶ Ask the groups to summarize their discussions.
- ▶ Ask each group to tell their summaries to the rest of the participants.
- ▶ Allow open discussion of the rights of the child and how, as adults, we have a special responsibility to ensure that the rights of children are protected.

OPTIONAL

Activity 7

Give participants the following quiz (see page 90).

Note: The questions in the quiz have been designed to have a true/false answer, to stimulate discussion.

Human Rights and Duties Quiz

Quiz questions – true or false?	Answer
1. The Universal Declaration of Human Rights was written in the year 1900.	False
2. The Commission that drafted the Universal Declaration of Human Rights was chaired by a woman.	True
3. All countries in the United Nations have promised to promote peace and human rights.	True
4. Food, shelter and the death penalty are examples of human rights.	False
5. Murder, torture and arbitrary imprisonment are violations of human rights.	True
6. The United Nations cannot do anything when governments commit human rights violations.	False
7. Governments should make national laws and legal systems that correspond to the human rights treaties they have ratified.	True
8. Children are not included in any human rights treaties.	False
9. Under human rights treaties, governments cannot deny rights to girls and women because of their sex.	True
10. Governments must try to provide free and compulsory education.	True
11. The Convention on the Rights of the Child states that children under 15 should not be recruited to armies or militias.	True
12. Refugees do not have any rights because they are not in their own countries.	False
13. Refugees have the right to resettlement in a country of their choice.	False
14. The 1981 African Charter on Human and People’s Rights gives the right to national and international peace and security, and to environmental protection.	True
15. Human rights agreements always mention rights but never duties and responsibilities.	False
16. The 1949 Geneva Conventions forbid the maltreatment of prisoners of war and civilians.	True
17. The mandate of the International Committee of the Red Cross and Red Crescent (ICRC) is limited to setting up hospitals for the war-wounded.	False
18. Human rights declarations and treaties, and international humanitarian law, are attempts to create up-to-date, worldwide standards that governments and others in authority should aim for, so that human beings are treated with respect and dignity.	True

Human Rights and Duties Quiz: Background Information

Note: The subject of human rights is very complex. Many different treaty articles, customary law, precedents and issues have to be reviewed in any given context. For example, we can talk of *moral* rights, or rights under *law*. The focus in the quiz is on international standards accepted by governments, through international declarations or treaties. The explanations provided are in simple layman's terms. They are not meant to be a full discourse on the subject of human rights: they serve only as an introduction.

1. The Universal Declaration of Human Rights was written in the year 1900.

False. The Universal Declaration of Human Rights was adopted and proclaimed by the United Nation's General Assembly in 1948, to be 'a common standard of achievement for all peoples and all nations'. It was intended to clarify the meaning of the term 'human rights', which had been used in the Charter of the United Nations. It has been re-affirmed by the General Assembly several times, and by the 1993 World Conference on Human Rights. It has inspired many national constitutions, as well as the 1966 International Covenants on Human Rights, and the regional human rights treaties of Europe, Africa and the Americas.

2. The Committee that drafted the UDHR was chaired by a woman.

True. Mrs. Eleanor Roosevelt, widow of the former United States president, chaired the discussions and negotiations. Perhaps this is why the United Nation's Charter and Universal Declaration of Human Rights use the term 'human rights', whereas in earlier times people spoke of the 'rights of man'.

3. All countries in the United Nations have promised to promote peace and human rights.

True. The United Nation's Charter, signed in 1945, stated that the signatory countries would work together to promote peace and fundamental human rights, the dignity and worth of the human person, the equal rights of men and women. Article 55 of the Charter says that the United Nations shall promote 'universal respect for, and observance of, human rights and fundamental freedoms for all without distinction as to race, sex, language or religion. Article 56 states that 'all members pledge themselves to take joint and separate action in co-operation with the Organisation for achievement of the purposes set out in Article 55'.

4. Food, shelter and the death penalty are examples of human rights.

False (about the death penalty). The Universal Declaration of Human Rights and human rights treaties protect the right to life, which requires food and shelter. Regarding the death penalty, there is a second optional protocol (1989) for those countries who do not have the death penalty as those governments consider it an infringement of the right to life.

5. Murder, torture and arbitrary imprisonment are violations of human rights.

True. For example, they violate the Universal Declaration of Human Rights and the 1966 International Covenant on Civil and Political Rights. There is a 1984 Convention against Torture and Other Cruel, Inhuman or Degrading Treatment or Punishment.

6. The United Nations cannot do anything when governments commit human rights violations.

False. Most human rights treaties have a committee to which governments must send reports on their implementation of the treaty. These include the Human Rights Committee (for the International Covenant on Civil and Political Rights), the Committee against Torture (for the Convention against Torture and Other Cruel, Inhuman or Degrading Treatment or Punishment), and the Committee on the Rights of the Child (for the Convention on the Rights of the Child). These Committees can ask governments to explain things that are not clear from their reports.

If a country has ratified the Optional Protocol to the International Covenant on Civil and Political Rights, then individuals from that country can complain to the Human Rights Committee about human rights abuses they have suffered (after exhausting all legal remedies in their home country, if this is practicable).

Since 1984, the chairpersons of these committees have met to review problems of implementation of the key human rights treaties.

The Human Rights Commission (established in 1946 by the Economic and Social Council (ECOSOC) of the United Nations; its first task was drafting the Universal Declaration of Human Rights) was asked to find ways of responding to individual complaints about human rights violations, that are received by the UN Secretary General. In 1970, ECOSOC's Resolution 1503 led to a procedure whereby a Working Group meets in Geneva each year to review incoming communications, and pass them up the system (through a Sub-Commission on to the Human Rights Commission). The Human Rights Commission can establish a Working Group or appoint a rapporteur under ECOSOC's 1967 Resolution 1235, to consider a particular human rights topic or to provide expert advisory services to countries.

Although these procedures are often slow and cumbersome, governments do not like to face the embarrassment of such proceedings, so they have some influence. Also, aid donors follow these proceedings and sometimes reduce their aid where there are reports of frequent human rights abuses. Further, the individual complaints help keep the UN informed of problems, even when those particular complaints are not followed up by the various committees mentioned above.

It should be emphasized, however, that the major influence of human rights treaties is through 'standard-setting' for national laws and legal procedures. These treaties and the Universal Declaration of Human Rights can also help communities check themselves informally against internationally accepted standards.

Following the 1993 World Conference on Human Rights, the post of UN High Commissioner for Human Rights was created in 1994, to strengthen the work of the UN in this area.

7. Governments should make national laws and create legal systems that correspond to the human rights treaties they have ratified.

True. See previous explanation.

8. Children are not included in any human rights treaties.

False. Children are protected as human beings under human rights treaties. Moreover, the 1989 Convention on the Rights of the Child is the most widely ratified human rights treaty (only two countries have not ratified it at the time of writing).

9. Under human rights treaties, governments cannot deny rights to girls and women because of their sex.

True. Discrimination by sex, race or religion is condemned under Article 55 of the UN Charter and in international and regional human rights treaties. Moreover, there is a 1979 Convention on the Elimination of All Forms of Discrimination against Women. (Discrimination by race is forbidden under the 1965 International Convention on the Elimination of All Forms of Racial Discrimination.)

10. All governments must try to provide free and compulsory basic education.

True. This is included in the Universal Declaration of Human Rights, in the 1966 International Covenant on Social, Economic and Political Rights and in the 1989 Convention on the Rights of the Child, for example. Education is an example of a 'progressive' right. Governments have promised to move towards these rights as fast as possible. (Some rights are absolute rights, non-derogable: life; freedom from torture and cruel, inhuman or degrading treatment or punishment; freedom from slavery and servitude; not to be imprisoned for debt; recognition as a person before the law; freedom of thought, conscience and religion; criminal laws not to be retrospective.)

11. The Convention on the Rights of the Child states that children under 15 should not be recruited to armies or militias.

True. At the time of writing, many countries (and NGOs) want to create an optional Protocol (an annex) to the Convention, for governments to promise not to recruit young persons for military service below age 18. (Note. The Convention on the Rights of the Child mostly applies to everyone under age 18, except in countries where the legal age for becoming an adult is less than this.)

12. Refugees do not have any rights because they are not in their own countries.

False. When a government signs a human rights treaty such as the International Covenants or the Convention on the Rights of the Child, the government has promised to protect the human rights of everyone within its boundaries. Also, the provisions of the Universal Declaration of Human Rights have become a kind of international customary law. In countries that have ratified the 1951 Convention relating to the Status of Refugees and its 1967 Protocol, there are specific rights protecting refugees.

The United Nations High Commissioner for Refugees (UNHCR) is mandated to provide protection and assistance towards a durable solution for refugees. It can often protect and assist refugees under its own mandate ('mandate refugees') where they are not recognized by the host government.

13. Refugees have the right to resettlement in a country of their choice.

False. Under the 1951 Convention, refugees have the right to non-refoulement. This means that they should not be sent back to their home country, when they are trying to leave it because of persecution and danger. After the country they enter gives them asylum, there is no automatic right to resettlement somewhere else.

14. The 1981 African Charter on Human and People's Rights gives the right to national and international peace and security, and to environmental protection.

True. The Organisation for African Unity (OAU) (now the African Union) adopted the Charter at a summit in 1981. As a modern document, it is noteworthy for mentioning the Universal Declaration of Human Rights as a standard, for including 'collective rights' or 'people's rights' including the equality of peoples; economic, social and cultural development; national and international peace and security; and a satisfactory environment. It is also the first human rights treaty to elaborate the fact that rights are linked to duties, to human solidarity within the family and wider society.

15. Human rights documents always mention rights but never duties and responsibilities.

False. The Universal Declaration of Human Rights was intended to be used as a checklist for our own behaviour and that of 'every organ in society', and to be disseminated by teaching and education. It is clear from the document that each right implied by someone implies duties for others. However, the first document to spell out this relationship clearly was the 1981 African Charter (see above).

16. The 1949 Geneva Conventions forbid the maltreatment of prisoners of war and civilians.

True. It is important to note that each Convention has the same 'Article 3', which forbids murder, cruelty and degrading treatment.

17. The mandate of the International Committee of the Red Cross and Red Crescent (ICRC) is limited to setting up hospitals for the war-wounded.

False. The ICRC mandate includes visiting prisoners of war, and delivering mail and food parcels to them. They also deliver humanitarian aid to civilians in the midst of armed conflict and conduct tracing of missing persons. ICRC is also involved in training armed forces to respect humanitarian law. They extend and develop the Geneva Conventions, acting as go-betweens for the release of prisoners of war, etc.

18. Human rights declarations and treaties, and international humanitarian law, are attempts to create up-to-date, worldwide standards that governments and others in authority should aim for, so that human beings are treated with respect and dignity;

True

Remarks.

Sometimes human rights are classified into three '*generations*'. Attention was first focused on civil and political rights, then on economic, social and cultural rights, and most recently on 'collective' rights, such as the right to development/peace/human rights/a satisfactory environment.

Often, one right has to be *balanced* against another. As a very simple example, making loud speeches outside a hospital could mean that the right to free expression of the people outside was conflicting with the right to health treatment of the people inside. In this case, the solution is probably simple. Often, however, the balancing of different rights requires careful attention.

Real-life problems and conflict resolution

160 minutes

Instructions

- ▶ Form the participants into small groups.
- ▶ Ask them to think about three or four real-life problem/conflict situations that they know well or are personally involved in. These should be listed on a flip chart or poster sheet.
- ▶ Check for overlap of problems and then assign one problem to each group (but not the problem that the group thought of).
- ▶ Ask the groups to work through the problem using all the skills they have developed in the course filling in the sheet below and using Appendix 14.
- ▶ Where the problem has multiple layers, the group should analyse the problem and state each layer.
- ▶ The 'underlying causes' of the problem need to be very specific. It is not enough to make a generalization. The group should discuss enough to be very sure that the list includes the real causes (beware of bias and lack of emotional honesty).
- ▶ The suggested solutions sections need to be solutions to the **causes, not** the problem. If the causes are not addressed, no resolution is possible.
- ▶ Allow as much time as necessary for this exercise.
- ▶ If groups feel that there are no problem/conflict situations, look specifically at girls' access and equity in education, domestic violence, attitudes towards minority groups (including, if appropriate, women and girls), human rights abuses.
- ▶ When the groups have worked through the sheet and developed possible solutions, these should be brought back and discussed with the whole group.

Stated	Underlying	Elements of	Suggested solutions
problem	causes	programme utilized	
e.g. girls are failing in school	Lack of community support for girls' education Ignorance of male teachers	Active listening (to the girls and the teachers) Communication Handling emotions Analytical thinking Problem-solving (focus on the solution you want)	Discussions with the community on the needs of the community vis-à-vis girls in school Extra support for girls (homework clubs) Special training for teachers on pedagogy and gender sensitivity (the gender sensitivity part can be done by people in the community who have girls in school)

Discussion

A great deal of analysis is required to undertake this effectively.

Discuss how the elements of Peace Education are cumulative and must all be used if there is to be a successful resolution to a problem/conflict situation.

Discuss the solutions offered to see how viable they are.

[Note: they should not involve somebody else 'giving' materials or a solution]

Discuss how these solutions can be put into effect by the community and develop a work-plan to undertake this, Peace Education in action!

As this is a response situation, you can only manage 'in-principle' preparation. This means keeping in mind all the lessons of Peace Education Programme.

Do not limit anything that the group wants to discuss, but be prepared to point out stereotypical judgements that groups may make or where they are arguing from a position of emotion rather than logic.

Review, if necessary, the session on problem-solving (Activities 11 and 12) on depersonalizing the problem. This is one reason why participants should be doing this exercise on other participants' specified problems.

Session 12 is to enable any further discussion or if sessions have carried over, to give the groups time to really discuss issues that are important to them.

It should be emphasized that this course is not an end, but rather a beginning. Ask participants to keep a record of how they respond to situations and what is different to the way they used to respond to similar situations.

Explain to the participants that they have built up the group dynamics and trust among themselves so that they can now rely on each other for support and advice.

Thank the participants and any people involved in the logistics.



Appendix 1

Conflict management continuum

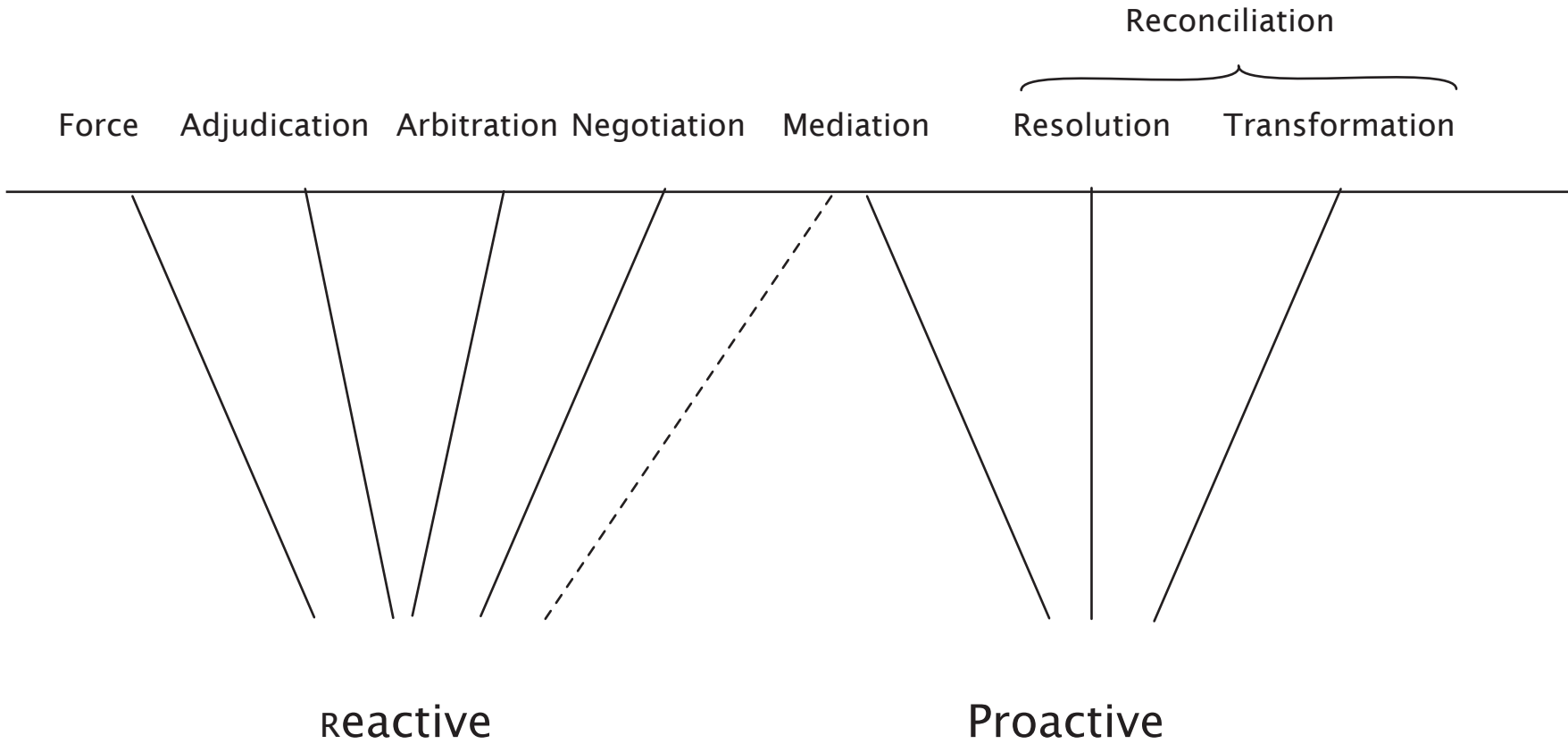

Appendix 2

Active Listening Skills

1. Listen to what the person is really saying.
2. Check that you have heard correctly by paraphrasing what the speaker has said and asking 'Is this what you mean?'
3. When the speaker has finished, summarise the main points and check with the speaker that your interpretation is accurate.
4. If the speaker is emotional (angry or sad), be very careful to listen to what is actually being said but remember to acknowledge the emotions.
5. Ask for clarification to check that you have the whole story.
6. Ask questions to fill in the details of the story if they are important.

Paraphrasing - saying the same thing in different words

Clarification - to make ideas or information clear.

Appendix 3

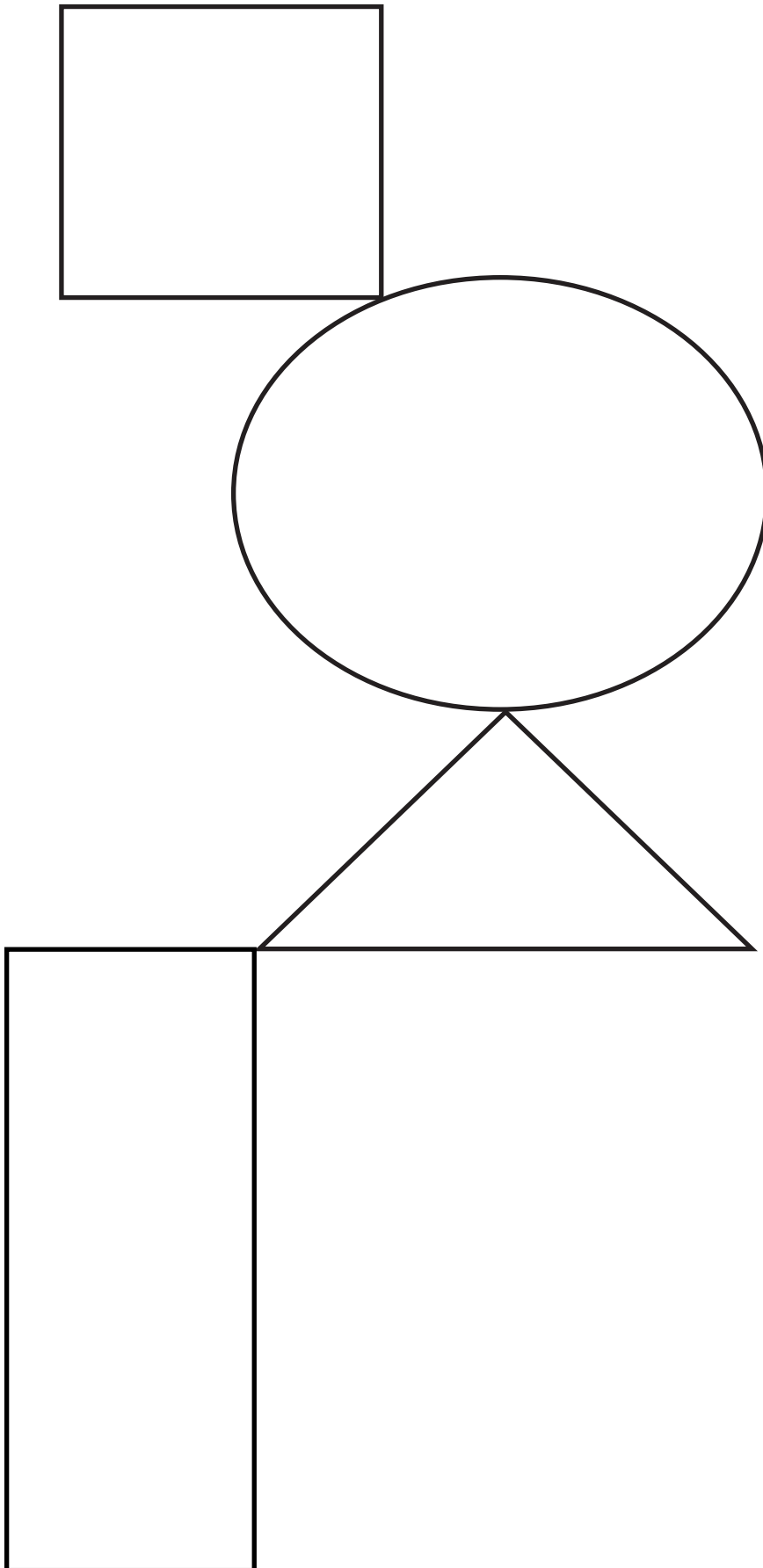

Appendix 4 Perception card

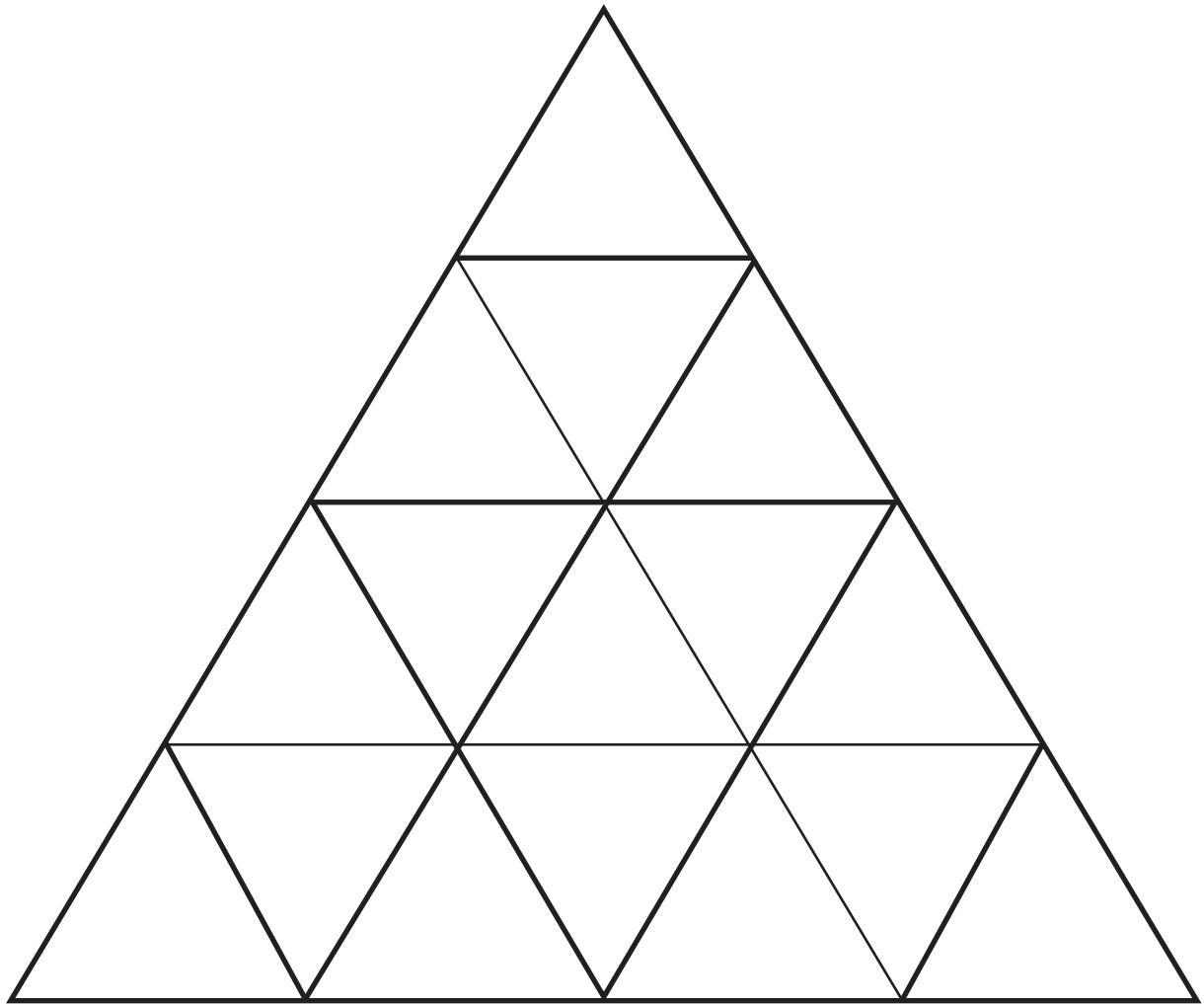

Appendix 4 (cont'd)

Appendix 4 (cont'd)

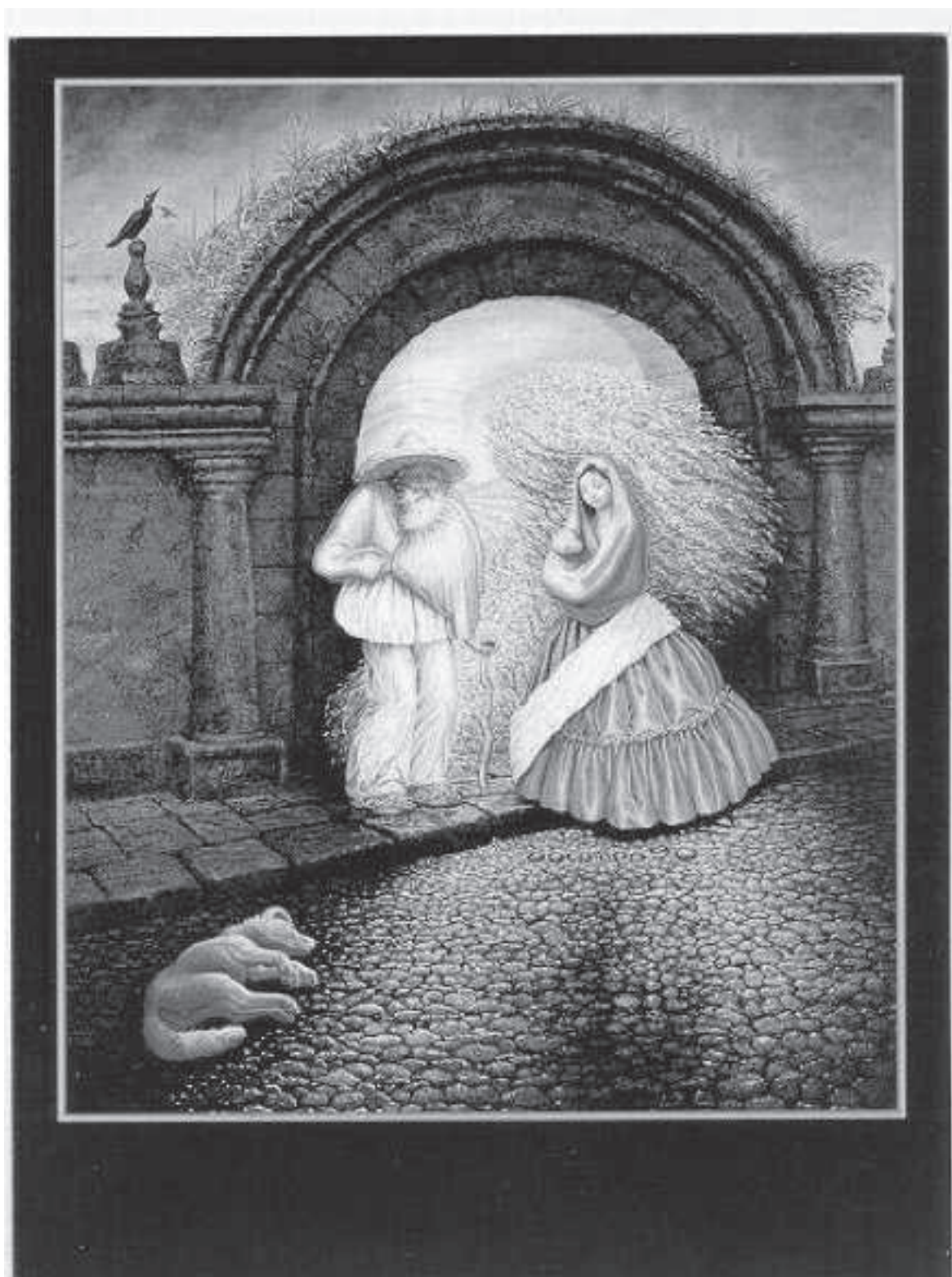

Appendix 4 (cont'd)



Appendix 5

AGGRESSIVE, ASSERTIVE AND SUBMISSIVE BEHAVIOUR

Aggressive:

- ▶ stand up for your own rights without caring for the rights of others
- ▶ make sure that you are okay no matter what happens to others
- ▶ accuse and blame others
- ▶ denigrate other people's point of view ('you must be stupid')

Assertive:

- ▶ stand up for your own rights while acknowledging the rights of others
- ▶ respect yourself and the other person
- ▶ listen to what the other person is saying
- ▶ express yourself clearly and honestly
- ▶ don't blame the other person

Submissive:

- ▶ take no action to assert your own rights
- ▶ put others before you at your own expense
- ▶ give in to what others want
- ▶ remain silent
- ▶ apologize more than is needed.

Appendix 6

APPROPRIATE ASSERTIVENESS

What you say	Principle of assertiveness
There is a problem about.....	Depersonalize the problem , discuss the problem, not the people involved.
I feel	No blame to the other person , the emphasis should be about how you feel not accusing the other person.
Because	Say why you feel as you do , this requires emotional honesty and an ability to be objective about the problem.
What do you think?	Clarification of problem , this requires both sides to really listen to make sure that both sides really understand all the points of view.
Would you be able to ...? Perhaps we could....	Presenting options , it is important look for constructive solutions (otherwise it is an accusation to the other person). This requires thought and work (which is perhaps why people don't do it very often).
Agree on a solution	Assertiveness takes into account the rights of the other person as well as your own rights. This does not mean what the other person necessarily claims as their rights - it means the right to be treated with respect and dignity.

Appendix 7

Constructive (reasonable) behaviour		Destructive behaviour	
	Assertiveness	Aggression	Submission
Elements of behaviour			
Possible positive effects			
Possible negative effects			

Appendix 8 - Solutions to problems

Activity 2

Numbers

This is one possible solution.

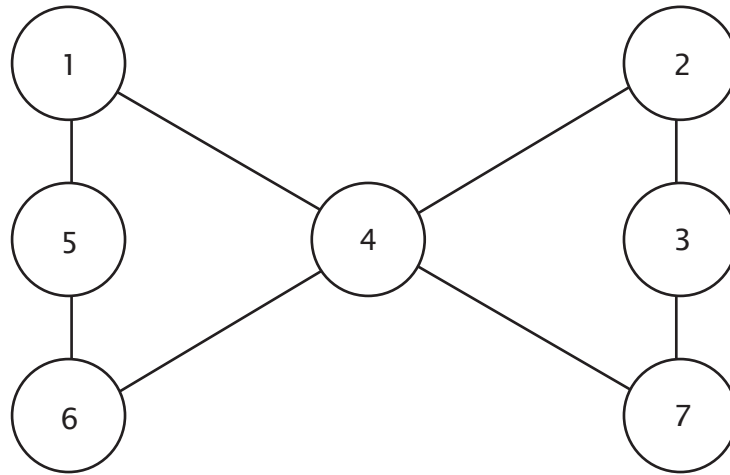

Hints for participants

Which is the middle number?

Where do you think that number would go?

Activity 3

The Snake and Houses

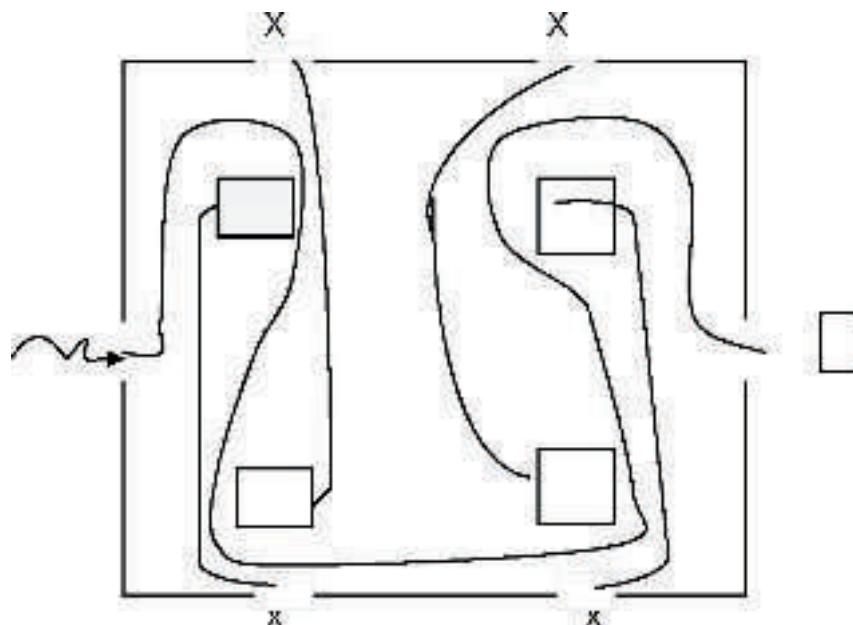

Hints for participants:

It is easier to take the people home first.

There is no rule that the people have to walk the most direct routes to their houses.

There is no rule that the snake has to travel in a straight line.

Activity 4

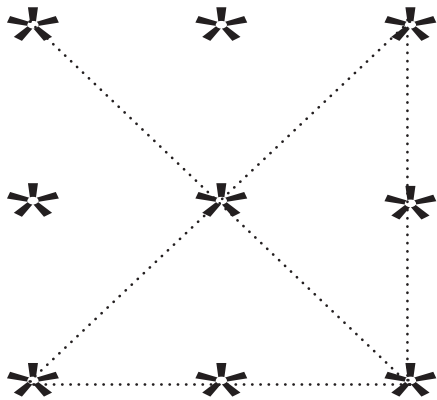

Hints for participants

Is there a square?

Do the lines have to stay inside the square?

Activity 7

The fox, the goat and the cabbage

Hints for Participants

Does each thing only make one trip?

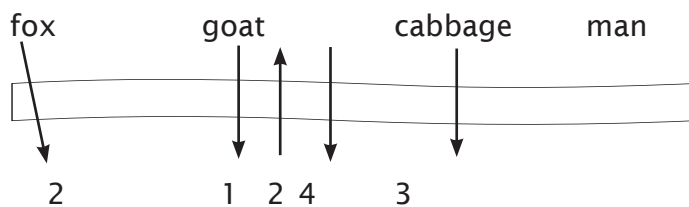

One possible Solution:

first trip: man and goat

second trip: man and fox, return trip with goat, leave fox,

third trip: man and cabbage,

fourth trip: man and goat.

Activity 8

Sharing the oil

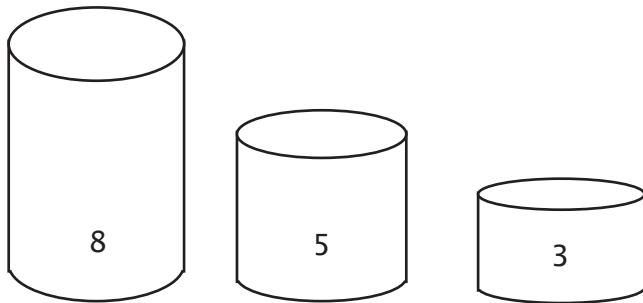

One solution is as follows:

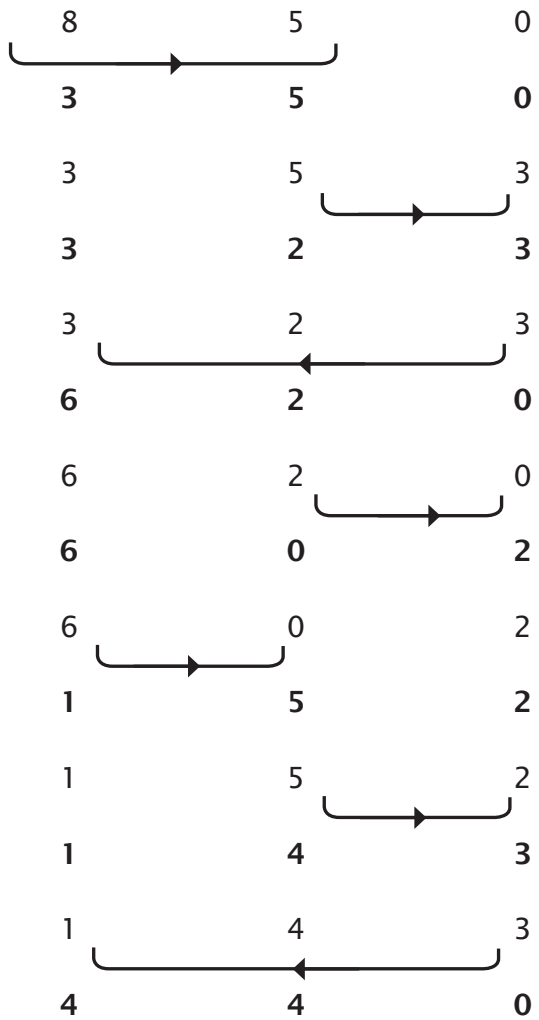

Appendix 9

SIX STEPS TO PROBLEM-SOLVING

What do you want?	Each side should say what they want but without blame or accusation
What is the problem?	Both sides must agree on the problem (i.e. identify the same problem)
How many solutions can we find?	Both sides need to propose as many alternative solutions as possible so that there is a choice and the best possible solution is found
Would you be happy with this solution?	Both sides need to look at the possible solutions and disregard only those that are totally unacceptable.
What is the best solution?	Both sides should agree on the best solution for everybody.
Is the problem solved?	After some time, we may need to check that the solution is really working.

Adapted from UNICEF, *Education for Conflict Resolution. A Training Manual*, New York, UNICEF, 1997

Appendix 10

NEGOTIATION QUESTIONS

For individual reflexion.

What feelings or emotions do you have about this problem?

What do you really need? Is this different to what you want?

If you concentrate on what you really need, is it possible to compromise?

What behaviours do you show that may stop the other person from getting their needs met?

Does the problem change in the course of the conflict?

How is the problem resolved?

Appendix 11

Rules for negotiation

Keep the problem and the people separate.

Look at the problem objectively, without concentrating on the personalities involved.

Concentrate on responding to needs (of those involved) not positions (i.e. not their perceived status, or emotional state).

Find as many options as possible to answer the other person's needs.

Be as objective as possible.

Seek a win/win solution.

Appendix 12

Mediation Checklist

Do you actively listen to each protagonist?

Have you checked yourself for any bias or discrimination?

Do the protagonists actively listen to each other?

Do the protagonists actively listen to you?

Are the protagonists communicating clearly?

Are they emotional?

Are they honest?

Are you honest?

Do you feel that the protagonists trust you?

Have you looked for areas where the protagonists are willing to compromise?

How many alternative solutions can the group come up with?

Can you find a solution that is acceptable to both sides?

Do the protagonists feel that they can forgive each other?

Is there a reconciliation?

Appendix 13

T I M E		First person (person who has been most wronged)	Second person (person who has most offended)
	Problem or conflict situation	→	
	Reactions	Denial Why has this happened to me? Why did she/he do this? It must be my fault! (submissive behaviour)	Denial I didn't do it! You forced me to behave that way (aggressive behaviour)
		Hurt There is a focus on the emotional pain caused (submissive behaviour)	Anger Where the person becomes angry and resentful at being put in the 'wrong' (aggressive behaviour)
		Anger There is a focus on blaming the other person (aggressive behaviour)	Remorse Where the person wants to relieve his/her conscience and guilt
		Empathy Where there is understanding of the other's emotions and an attempt to understand the motives behind the wrongdoing	Empathy Where there is understanding of the other's emotions and an attempt to understand the hurt and anger
		Resolution Where the problem is 'depersonalized' and solutions are sought and agreed to	Resolution Where the problem is 'depersonalized' and solutions are sought and agreed to
		Forgiveness Internal peace and 'letting go' of the pain	Asking forgiveness If genuine, then an internal peace and 'letting go' of the anger and the aggression
		Reconciliation	Reconciliation

Appendix 14

ELEMENTS OF ANALYSING THE CONFLICT SITUATION

- ▶ What is wrong?
- ▶ What outcome does each person want?
- ▶ What is fair for each person?
- ▶ What is most important for each person?
- ▶ What things do both sides agree on?
- ▶ Is one person absolutely right and the other person absolutely wrong?
- ▶ Is either side willing to admit that it is wrong? Why or why not?
- ▶ Is either side angry? Does anger affect how he/she acts? Is the anger justified?
- ▶ Can the two people solve their problem?